

XS8 Series

Technical Guide

Submersible electropumps
and motors for 8" wells

50 Hz

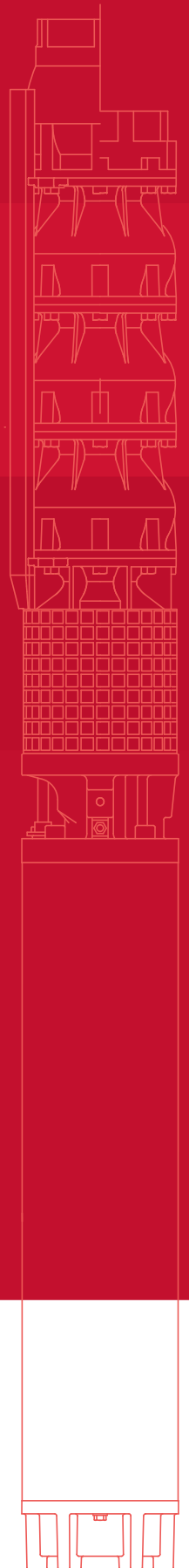
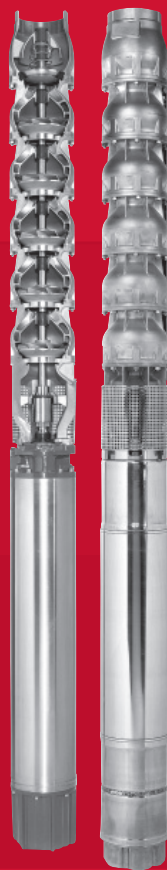

Sectors of application	4
Technical characteristics	5
Table of materials and identification data	6
Hydraulic performance field 50 Hz at 2900 rpm	7
Operating dimensions, weights and curves	10-29
Pump section and component names	30
E6W 6” submersibles motors	32-34
CP8 8” submersibles motors	35-36
CP10 10” submersibles motors	37-38
Accessories	40-44
Notes	45-46

Submersible electropumps and motors for XS8 series 8" wells

The XS8 pump is a submersible pump for deep wells from 8". Can be coupled to any motor meeting the NEMA standard.

Sectors of applications: Agricultural and industrial. Version **XS8R**, suitable for operating with sea water.

- >> Water supply from deep wells.
- >> Pressurisation and distribution in civil and industrial facilities.
- >> Supply for autoclaves and cisterns.
- >> Fire-prevention and washing systems.
- >> Water table control.
- >> Irrigation.
- >> Mines.

Application range → XS8 at 2900 rpm

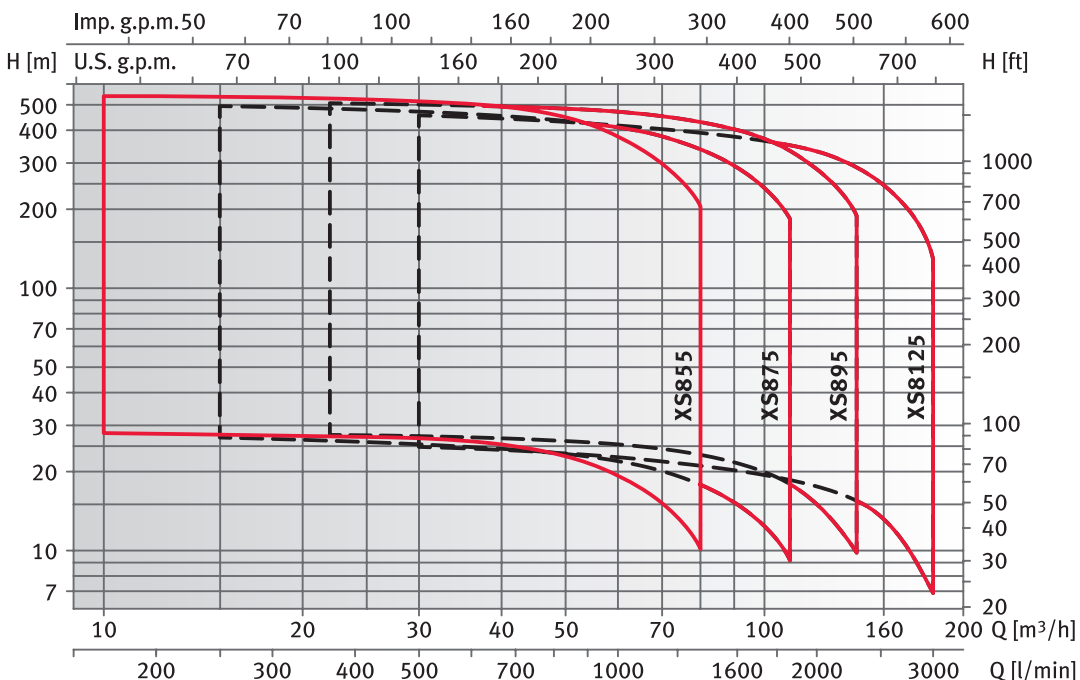

Curves obtained in accordance with ISO 9906 appendix A.

Description

- The **XS8** pump is a submersible pump for deep wells from 8".
- Maximum sand content in water 100 g/m³. Can be coupled to any motor meeting the NEMA standard. Easy to dismantle. Great resistance to corrosion.

Technical data

- Flow: up to 180 m³/h.
- Height: up to 550 m.
- Total maximum diameter of pump (including 2 cable sheaths): 198 mm for all versions.
- Maximum immersion depth of the electropumps: 250 m with **E6W** motors, 40 m with **C8** and **CP10** motor with standard configuration (with plug for shafts), on request version with mechanical seal (max. immersion depth 350 m).
- Maximum quantity of sand tolerated in water 100 g/m³.
- Standard discharge nozzle: Rp 5" for all version.
- Motor power: from 5,5 to 150 kW.

Electrical and motor specifications

- **E6W** motor: asynchronous, three-phase, immersed in water with hermetically sealed stator.
- **CP8** and **CP10** motors, rewindable, asynchronous, three-phase with winding in water.
- Three-phase version:
 - E6W**: from 3 to 37 kW 380-415V, 50 Hz.
 - CP8**: from 30 to 92 kW 380-415V, 50 Hz.
 - CP10**: from 92 to 150 kW 380-415V, 50 Hz.
- Maximum deviation from rated voltage:
 - E6W** 400V ±10%, **CP8**, **CP10** 400 V +6% -10%.
- PVC winding for **CP8** and **CP10** motors.
- Horizontal operation: **E6W** up to 37 kW provided the coupled pump is able to exert a minimum axial thrust of 250 N throughout the operating range, **CP8** and **CP10** on request in all version.
- Maximum number of hourly start-ups: 25 (**E6W**), 15 (**CP8**) and 10 (**CP10**).
- Maximum temperature of water in contact with the motor: 35°C (**E6W**), 25°C (**CP8** and **CP10**).

Buid specifications

- Robust and lightweight, easy to maintain and resistant to corrosion in non-aggressive atmospheres.
- Stainless steel impellers and diffusers.
- Stainless steel impulsion body.
- Stainless steel non-return valve with buit-in spring.
- Stainless steel suction support.
- Stainless steel shaft.
- Sliding bearings and wear rings guarantee resistance to wear and tear and assure constant operation and stability of the hydraulic performance over time.
- Joint and flange with coupling dimensions based on the NEMA standard.

Manufactured on request

- Different voltages and frequencies.
- High temperature versions.
- **CP8** and **CP10** for horizontal installations.
- Version available **XS8R** in DUPLEX stainless steel.

Accessories

- Coupling flange.
- Panels.
- Descending cables.

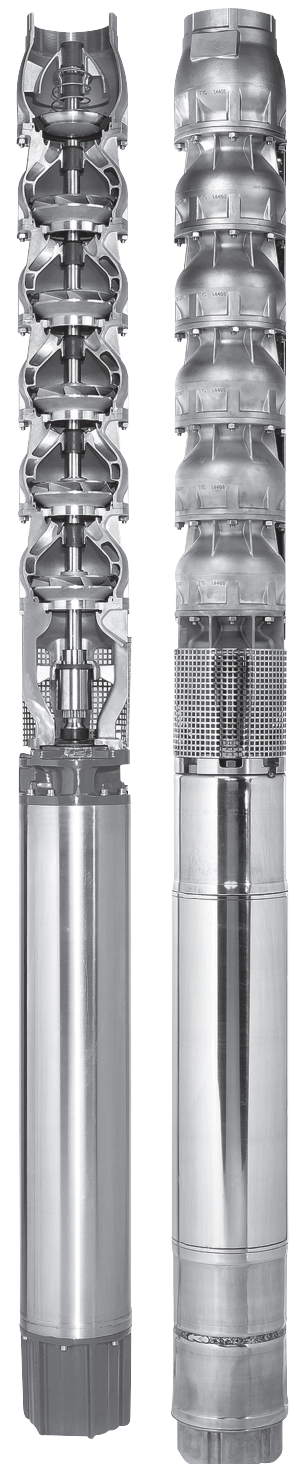

Table of materials of XS8

DESCRIPTION	MATERIALS	REF. STANDARDS EUROPE	REF. STANDARDS USA
Discharge body/valve body	Stainless steel	EN 10213-4-GX5CrNi19-10 (1.4308)	A744-CF 8
Valve	Stainless steel	EN 10213-4-GX5CrNi19-10 (1.4308)	A744-CF 8
Valve joint	NBR 90		
Valve spring	Stainless steel	EN 10088-1-X5CrNiMo17-12-2 (1.4401)	AISI 316
Diffuser	Stainless steel	EN 10213-4-GX5CrNi19-10 (1.4308)	A744-CF 8
Diffuser O-ring	NBR 70		
Impeller	Stainless steel	EN 10213-4-GX5CrNi19-10 (1.4308)	A744-CF 8
Impeller fastening cones	DUPLEX stainless steel	EN 10088-1-X2CrNiMoN22-5-3 (1.4462)	A276/A790-S31803
Friction rings	POM (DELRIN®)		
Lower suction support	Stainless steel	EN 10213-4-GX5CrNi19-10 (1.4308)	A744-CF 8
Filter	Stainless steel	DIN 17440-X6CrNiMoTi17-12-2 (1.4571)	AISI 316Ti
Pump shaft	Stainless steel	EN 10088-1-X17CrNi16-2 (1.4057)	AISI 431
Joint	Stainless steel	EN 10088-1-X17CrNi16-2 (1.4057)	AISI 431
Bushing bearings	EPDM + LOXAMID®		
Shaft box support	PTFE + 25% graphite		
Screws	Stainless steel	ISO 3506-1/2 A4-70	AISI 316
Cable sheaths	Stainless steel	EN 10088-1-X5CrNi18-10 (1.4301)	AISI 304

Table of materials for XS8R

DESCRIPTION	MATERIALS	REF. STANDARDS EUROPE	REF. STANDARDS USA
Discharge body/valve body	DUPLEX stainless steel	EN 10213-4-GX2CrNiMoCuN25-6-3-3 (1.4517)	
Valve	DUPLEX stainless steel	EN 10213-4-GX2CrNiMoCuN25-6-3-3 (1.4517)	
Valve joint	NBR 90		
Valve spring	Hastelloy C4	DIN 17744-NiMo16Cr16Ti (2.4610)	N06455
Diffuser	DUPLEX stainless steel	EN 10213-4-GX2CrNiMoCuN25-6-3-3 (1.4517)	
Diffuser O-ring	NBR 70		
Impeller	DUPLEX stainless steel	EN 10213-4-GX2CrNiMoCuN25-6-3-3 (1.4517)	
Impeller fastening cones	DUPLEX stainless steel	EN 10088-1-X2CrNiMoN22-5-3 (1.4462)	A276/A790-S31803
Friction rings	POM (DELRIN®)		
Lower suction support	DUPLEX stainless steel	EN 10213-4-GX2CrNiMoCuN25-6-3-3 (1.4517)	
Filter	Stainless steel	EN 10088-1X1NiCrMoCu25-20-5 (1.4539)	AISI 904L
Pump shaft	DUPLEX stainless steel	EN 10088-1-X2CrNiMoN22-5-3 (1.4462)	A276/A790-S31803
Joint	DUPLEX stainless steel	EN 10088-1-X2CrNiMoN22-5-3 (1.4462)	A276/A790-S31803
Bushing bearings	EPDM + LOXAMID®		
Shaft box support	PTFE + 25% graphite		
Screws	DUPLEX stainless steel	EN 10088-1-X2CrNiMoN22-5-3 (1.4462)	A276/A790-S31803
Cable sheaths	Stainless steel	EN 10088-1X1NiCrMoCu25-20-5 (1.4539)	AISI 904L

Identification data

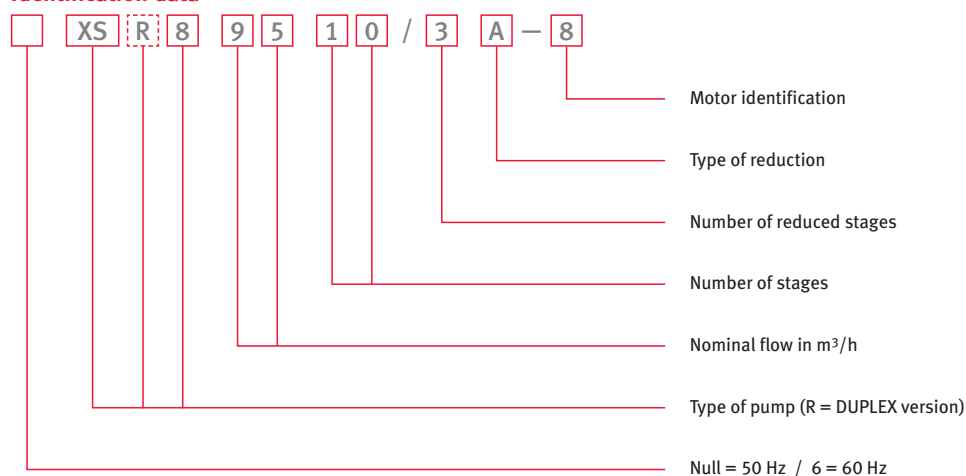

EXAMPLE: XS8 9510/3A - 8

8" electropump at 50 Hz, nominal flow 95 m³/h, 10 stages, 3 of which are reduced, coupled to an 8" CP8 motor.

XS8 Series

XS8 Series Hydraulic performance field 50 Hz at 2900 rpm



XS8 series

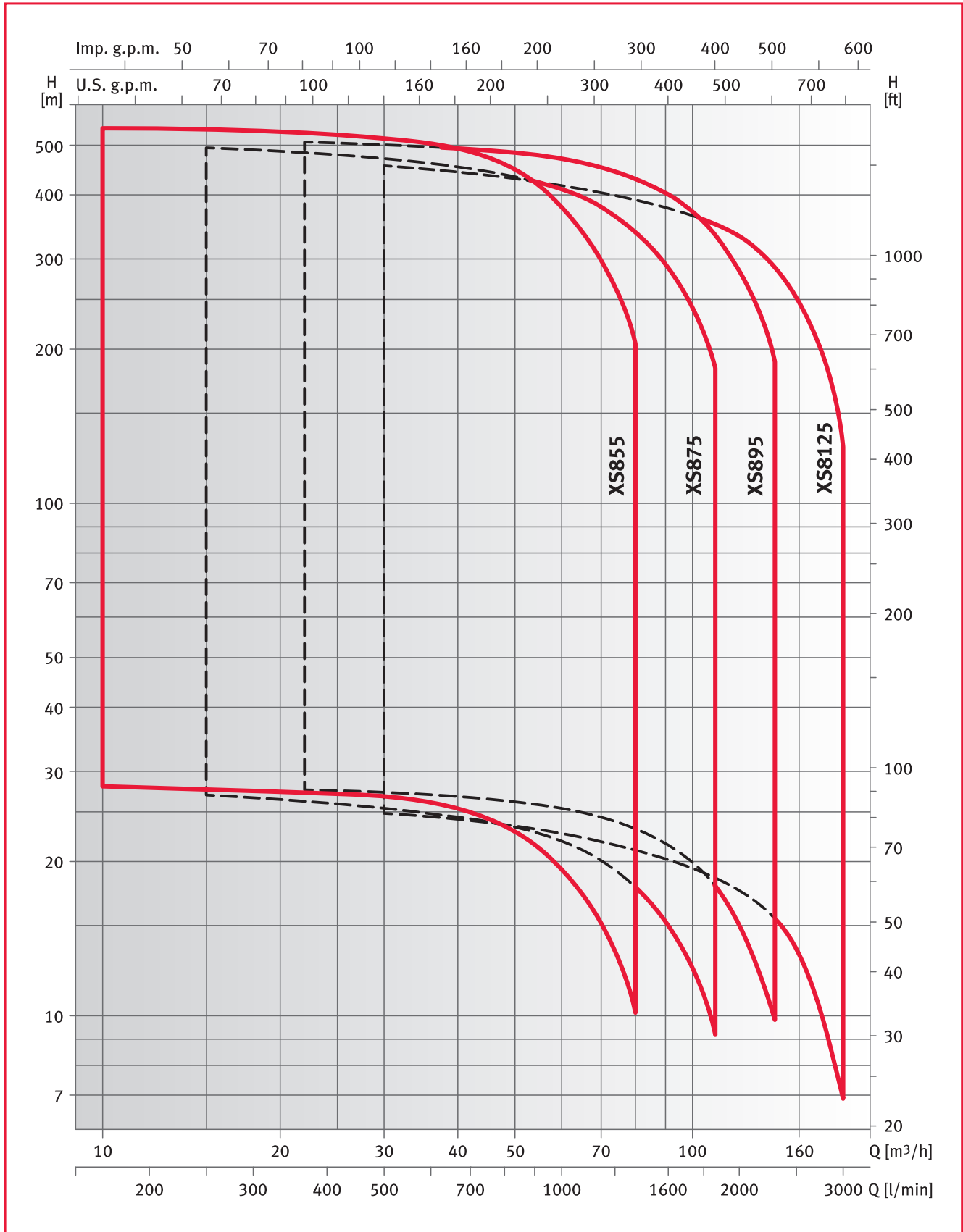

Pump performance valid for liquids with a density of $\rho = 1,0 \text{ kg/dm}^3$ and kinematic viscosity of $\nu = 1 \text{ mm}^2/\text{s}$.

XS8 Series

Operating dimensions,
weights and curves

50 Hz



XS855 series from 1 to 7 stages

PUMP TYPE	P2 kW	l/min m ³ /h	0	167	500	833	1217	1333
			0	10	30	50	73	80
XS855 01	5.5		28.7	28	27	23	14	10.2
XS855 02/2A	7.5		45.7	44.4	43	35	14.9	
XS855 02/1A	7.5		51.3	49.9	48	40	20.5	
XS855 02	9.3		57	55.6	53	45	27	19.7
XS855 03/2A	11		74.2	72.1	69	57	27.7	
XS855 03	15		86.1	83.9	80	69	41	30.7
XS855 04/2A	15		102.7	99.9	96	79	41	
XS855 04	18.5		114.6	111.7	107	91	55	40.7
XS855 05/3A	18.5		125.6	122.2	117	97	49	
XS855 05/2A	22		132.3	128.8	124	104	56.7	
XS855 05	22		143.5	139.8	134	114	68	50.5
XS855 06/2A	30		160.7	156.6	150	127	70.9	
XS855 06	30		172	167.6	160	137	83	61.3
XS855 07/2A	30		188.6	183.6	176	148	82.3	
XS855 07	30		199.7	194.5	186	158	93	68.8

XS855 series dimensions and weights

PUMP TYPE	DIMENSIONS (mm)				WEIGHT kg ⁽³⁾
	A ⁽⁴⁾	C ⁽¹⁾	M	Tmin ⁽²⁾	
XS855 01-6	1191	200	140	1631	70
XS855 02/2A-6	1355	200	140	1660	81
XS855 02/1A-6	1355	200	140	1660	81
XS855 02-6	1380	200	140	1685	84
XS85503/2A-6	1560	200	140	1730	97
XS855 03-6	1615	200	140	1785	103
XS855 04/2A-6	1750	200	140	1785	112
XS855 04-6	1825	200	140	1860	119
XS855 05/3A-6	1960	200	140	1860	128
XS855 05/2A-6	2020	200	140	1920	134
XS855 05-6	2020	200	140	1920	134
XS855 06/2A-6	2285	200	140	2050	155
XS855 06-6	2285	200	140	2050	155
XS855 07/2A-6	2420	200	140	2050	164
XS855 07-6	2420	200	140	2050	164

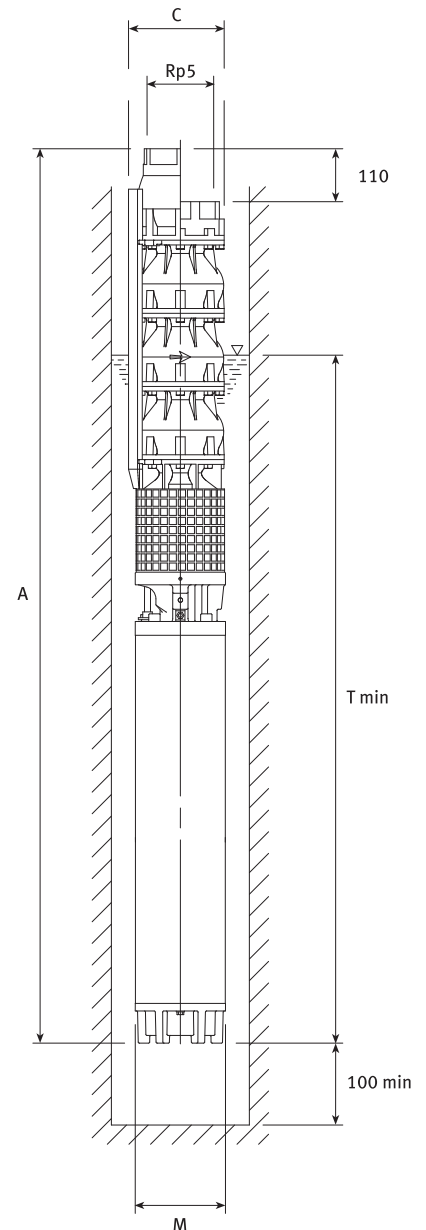

- 1. Max. diameter of the electropump including 2 motor cable outputs. In the case of 1 output cable C = 198 mm with **E6W** motor.
- 2. Tmin. OK for max. flow speed 4,2 m/s.
If this speed is higher contact the sales network.
- 3. Without cables.
- 4. If there is no non-return valve reduce elevation A to 110 mm and the weight to 4 Kg.

XS855 series from 1 to 7 stages

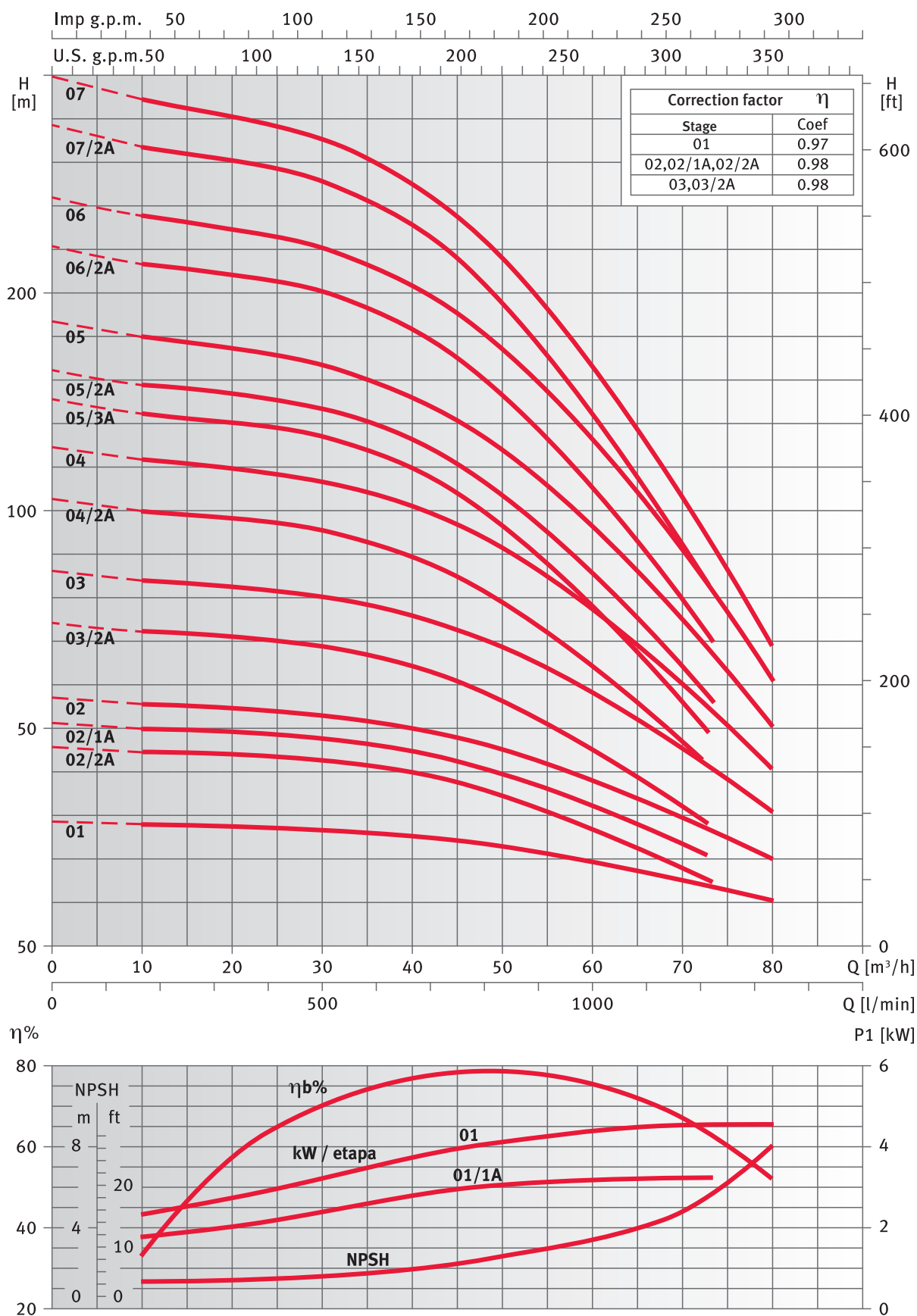

Load losses in the non-return valve included.
Performance valid for liquids with densities of $\rho = 1,0 \text{ kg/dm}^3$ and kinematic viscosity of $\nu = 1 \text{ mm}^2/\text{s}$.

XS855 series from 8 to 19 stages

PUMP TYPE	P2 kW	l/min m ³ /h	0	167	500	833	1217	1333
			0	10	30	50	73	80
XS855 08/2A	37		217	211.5	202.8	171	96.1	
XS855 08	37		228.3	222.5	212.7	181	107.3	79.4
XS855 09/2A	37		244.8	238.3	227.8	191.2	106.8	
XS855 09	44		260.6	254.2	244.3	210.6	128.5	96.9
XS855 10/2A	44		277.5	270.5	260.1	221.5	128.4	
XS855 10	44		288.8	281.7	270.3	231.9	140.2	105.2
XS855 11/2A	52		305.6	298	286.6	244.8	143.2	
XS855 11	52		316.9	309.2	296.8	255.4	155.4	116.9
XS855 12	55		346.6	338.3	324.8	279.8	170.5	128.5
XS855 13	59		375.3	366.1	351.3	302.3	183.7	138.2
XS855 14	66		404.5	394.7	379.1	326.6	198.9	149.9
XS855 15	66		432.8	422.2	404.9	348	210.9	158.4
XS855 16	75		461.6	450.3	432.1	372.2	226.5	170.5
XS855 17	92		491.8	479.8	461.2	398.8	244.6	185
XS855 18	92		520	507.3	487.4	420.8	257	194
XS855 19	92		551.2	538	517	446.3	273.5	206.9

XS855 series dimensions and weights

PUMP TYPE	DIMENSIONS (mm)				WEIGHT kg ⁽³⁾
	A ⁽⁴⁾	C ⁽¹⁾	M	Tmin ⁽²⁾	
XS855 08/2A-6	2685	200	140	2180	186
XS855 08-6	2685	200	140	2180	186
XS855 09/2A-6	2820	200	140	2180	194
XS855 09-8	2835	203.3	192	2195	276
XS855 10/2A-8	2970	203.3	192	2195	284
XS855 10-8	2970	203.3	192	2195	284
XS855 11/2A-8	3195	203.3	192	2285	313
XS855 11-8	3195	203.3	192	2285	313
XS855 12-8	3370	203.3	192	2325	328
XS855 13-8	3555	203.3	192	2375	347
XS855 14-8	3780	203.3	192	2465	374
XS855 15-8	3915	203.3	192	2465	382
XS855 16-8	4140	203.3	192	2555	408
XS855 17-8	4475	203.3	192	2755	455
XS855 18-8	4610	203.3	192	2755	463
XS855 19-8	4745	203.3	192	2755	472

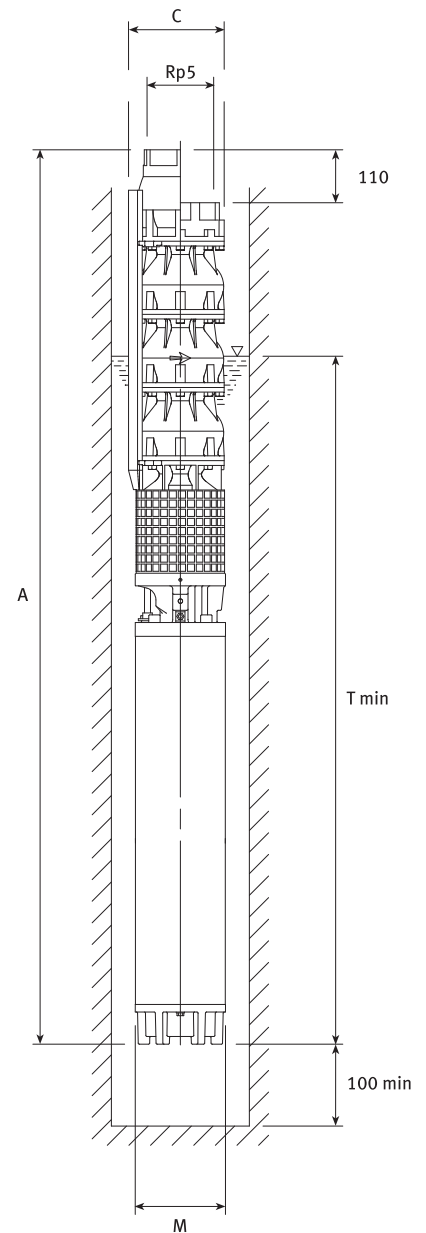

- 1. Max. diameter of the electropump including 2 motor cable outputs. In the case of 1 output cable C = 198 mm with **E6W** motor. C = 201,5 mm with **CP8** motor.
- 2. Tmin. OK for max. flow speed 4,2 m/s.
If this speed is higher contact the sales network.
- 3. Without cables.
- 4. If there is no non-return valve reduce elevation A to 110 mm and the weight to 4 Kg.

XS855 series from 8 to 19 stages

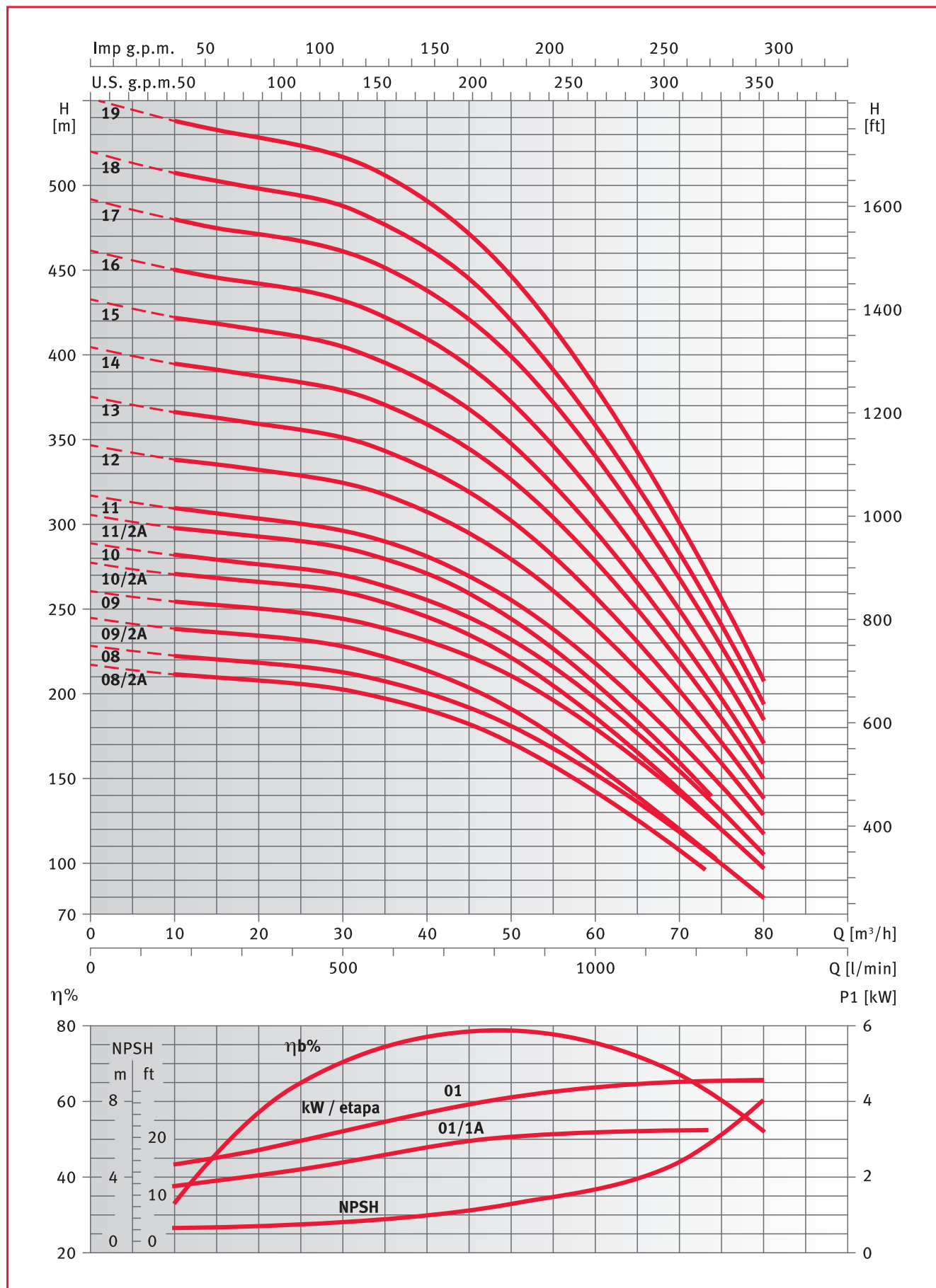

Load losses in the non-return valve included.
Performance valid for liquids with densities of $\rho = 1,0 \text{ kg/dm}^3$ and kinematic viscosity of $\nu = 1 \text{ mm}^2/\text{s}$.

XS875 series from 1 to 6 stages

PUMP TYPE	P2 kW	l/min m ³ /h	0	250	700	1167	1700	1833
			0	15	42	70	102	110
XS875 01	5.5		28.9	26.9	24.2	20.1	11.8	9.2
XS875 02/2A	7.5		44.1	42.1	38.2	29.3	11.3	
XS875 02/1A	9.3		50.8	48	43.3	34.7	17.6	
XS875 02	11		57.9	54.1	48.7	40.5	23.9	18.6
XS875 03/3A	11		66.1	63.1	57.2	43.7	16.9	
XS875 03/2A	15		73.5	69.7	63.3	50.4	24	
XS875 03/1A	15		80.1	75.3	68	55.3	29.8	
XS875 03	18.5		87.5	81.7	73.9	61.8	37	29.1
XS875 04/2A	18.5		102.3	96.5	87.4	70.3	35.6	
XS875 04	22		116.5	108.8	98.1	81.8	48.8	38.1
XS875 05/3A	22		124.7	117.9	106.7	85.2	41.4	
XS875 05/2A	30		132.1	124.4	112.9	92.1	49.3	
XS875 05	30		145.3	135.8	122.5	102.3	61	47.7
XS875 06/2A	30		160	150.4	135.9	110.6	59.7	
XS875 06/1A	30		166.5	156	140.6	115.5	65.8	
XS875 06	37		174.2	162.8	147.1	122.7	73.1	57.2

XS875 series dimensions and weights

PUMP TYPE	DIMENSIONS (mm)				WEIGHT kg ⁽³⁾
	A ⁽⁴⁾	C ⁽¹⁾	M	Tmin ⁽²⁾	
XS875 01-6	1208	200	140	1631	71
XS875 02/2A-6	1389	200	140	1660	82
XS875 02/1A-6	1414	200	140	1685	85
XS875 02-6	1459	200	140	1730	89
XS875 03/3A-6	1611	200	140	1730	99
XS875 03/2A-6	1666	200	140	1785	105
XS875 03/1A-6	1666	200	140	1785	105
XS875 03-6	1741	200	140	1860	112
XS875 04/2A-6	1893	200	140	1860	121
XS875 04-6	1953	200	140	1920	127
XS875 05/3A-6	2105	200	140	1920	137
XS875 05/2A-6	2235	200	140	2050	149
XS875 05-6	2235	200	140	2050	149
XS875 06/2A-6	2387	200	140	2050	159
XS875 06/1A-6	2387	200	140	2050	159
XS875 06-6	2517	200	140	2180	172

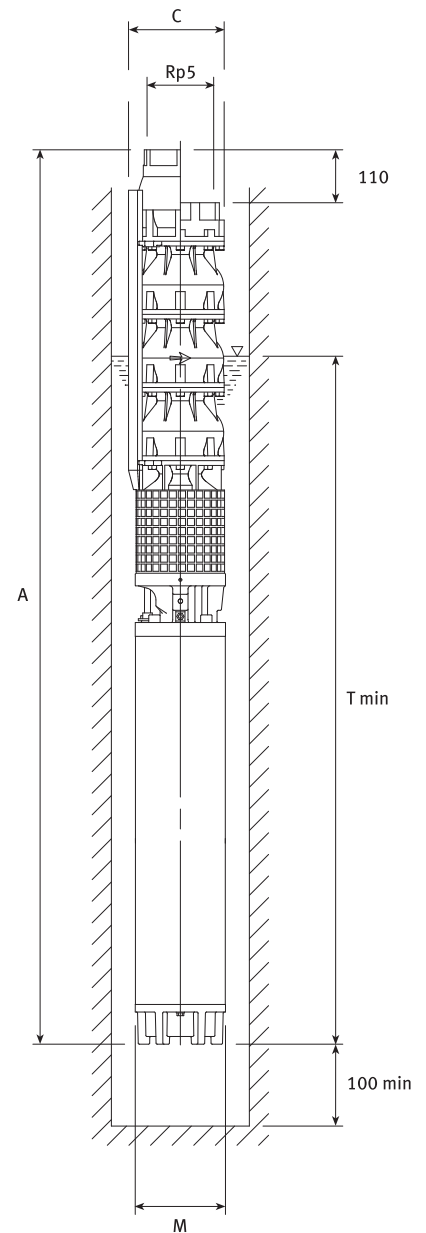

- 1. Max. diameter of the electropump including 2 motor cable outputs. In the case of 1 output cable C = 198 mm with **E6W** motor.
- 2. Tmin. OK for max. flow speed 4,2 m/s.
If this speed is higher contact the sales network.
- 3. Without cables.
- 4. If there is no non-return valve reduce elevation A to 110 mm and the weight to 4 Kg.

XS875 series from 1 to 6 stages

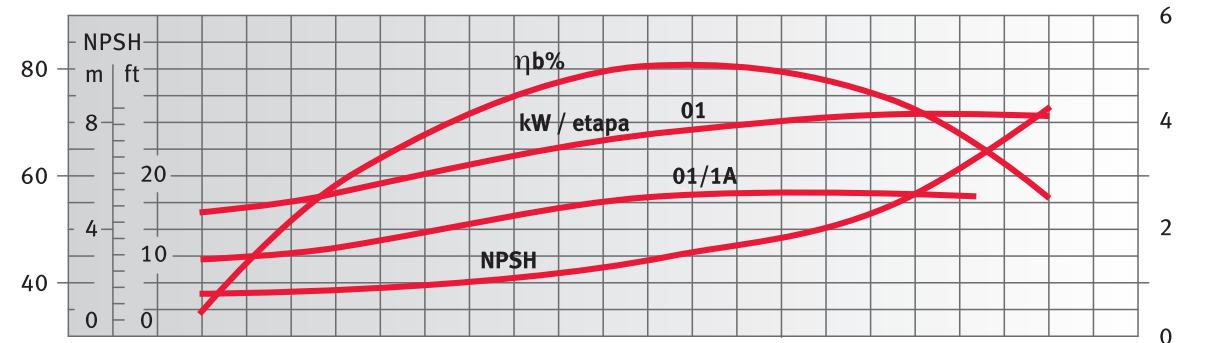
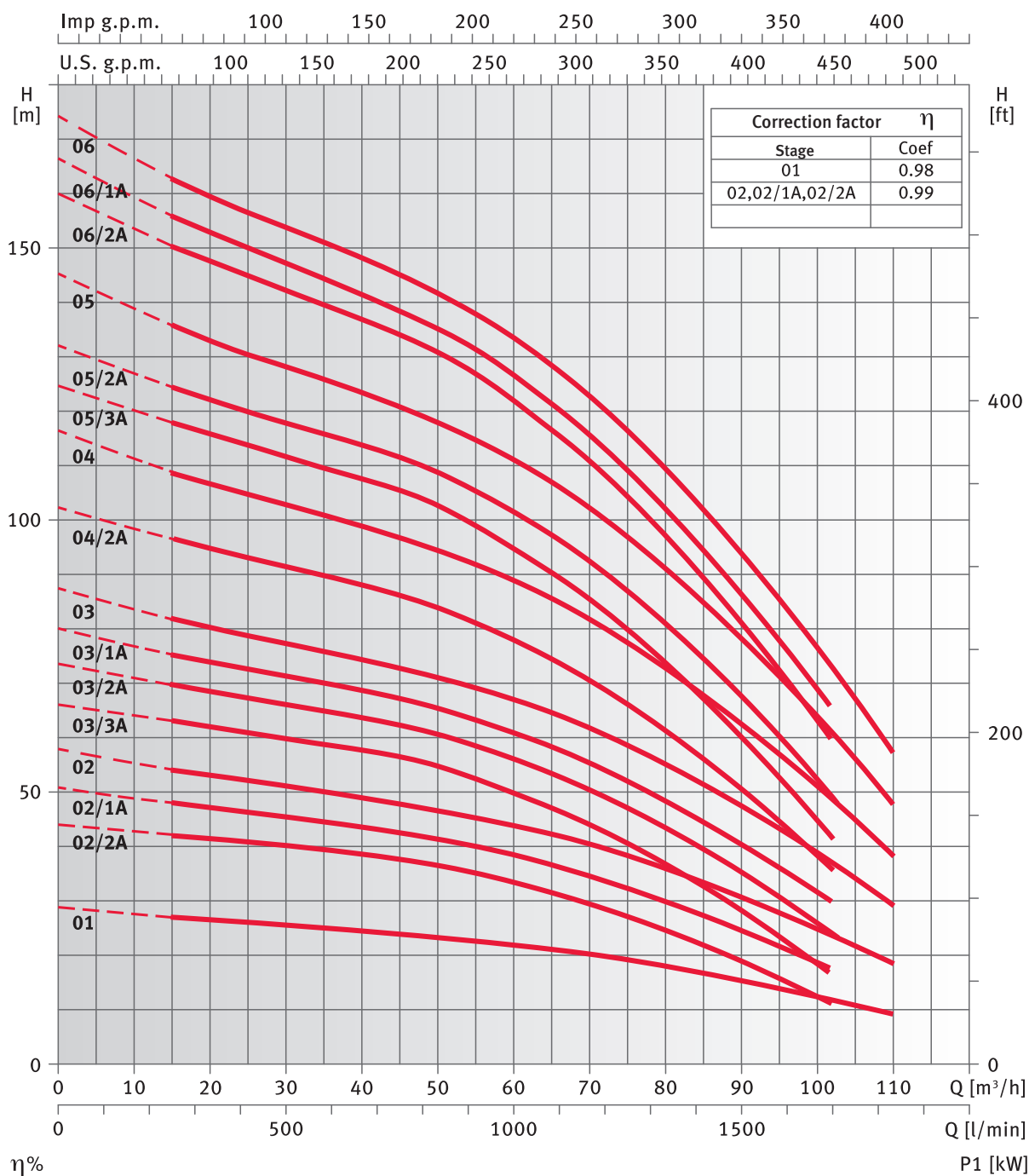

Load losses in the non-return valve included.
Performance valid for liquids with densities of $\rho = 1,0 \text{ kg/dm}^3$ and kinematic viscosity of $\nu = 1 \text{ mm}^2/\text{s}$.

XS875 series from 7 to 18 stages

PUMP TYPE	P2 kW	l/min m ³ /h	0	250	700	1167	1700	1833
			0	15	42	70	102	110
XS875 07/2A	37		189	177.5	160.4	131	71.8	
XS875 07	37		202	188.7	169.8	140.8	82.7	64.2
XS875 08/3A	37		210.1	197.7	178.3	143.9	76.7	
XS875 08/2A	44		221.1	208	188.9	156.2	88.7	
XS875 08	44		234.9	219.6	198.8	166.5	100.6	79.3
XS875 09/2A	44		249.9	234.6	212.4	175.1	99.1	
XS875 09	52		263.6	246.4	223	187.2	113.3	89.3
XS875 10/2A	52		278.5	261.3	236.7	196	112.1	
XS875 10	52		291.8	272.7	246.5	206.5	124.1	97.5
XS875 11/2A	55		308.6	298.4	262.1	217.4	125.1	
XS875 11	59		322.3	301.3	272.5	228.5	138	108.7
XS875 12	66		352.1	329.1	297.9	249.9	151.1	119.2
XS875 13	75		381.2	356.4	322.6	271	164.3	129.7
XS875 014	75		409.5	382.8	346.2	290.3	175.1	137.9
XS875 15	92		440.2	411.5	373	313.8	190.6	150.7
XS875 16	92		471.8	441.2	399.6	336	204.6	162.1
XS875 17	92		500.3	467.8	423.3	355.4	215.7	170.4
XS875 18	92		530.1	495.7	449.6	378.8	231.2	183.3

XS875 series dimensions and weights

PUMP TYPE	DIMENSIONS (mm)				WEIGHT kg ⁽³⁾
	A ⁽⁴⁾	C ⁽¹⁾	M	Tmin ⁽²⁾	
XS875 07/2A-6	2669	200	140	2180	181
XS875 07-6	2669	200	140	2180	181
XS875 08/3A-6	2821	200	140	2180	190
XS875 08/2A-8	2836	203.3	192	2195	271
XS875 08-8	2836	203.3	192	2195	271
XS875 09/2A-8	2988	203.3	192	2195	281
XS875 09-8	3078	203.3	192	2285	301
XS875 10/2A-8	3230	203.3	192	2285	310
XS875 10-8	3230	203.3	192	2285	310
XS875 11/2A-8	3422	203.3	192	2325	325
XS875 11-8	3472	203.3	192	2375	336
XS875 12-8	3714	203.3	192	2465	363
XS875 13-8	3956	203.3	192	2555	389
XS875 014-8	4108	203.3	192	2555	399
XS875 15-8	4460	203.3	192	2755	446
XS875 16-8	4612	203.3	192	2755	455
XS875 17-8	4764	203.3	192	2755	464
XS875 18-8	4916	203.3	192	2755	474

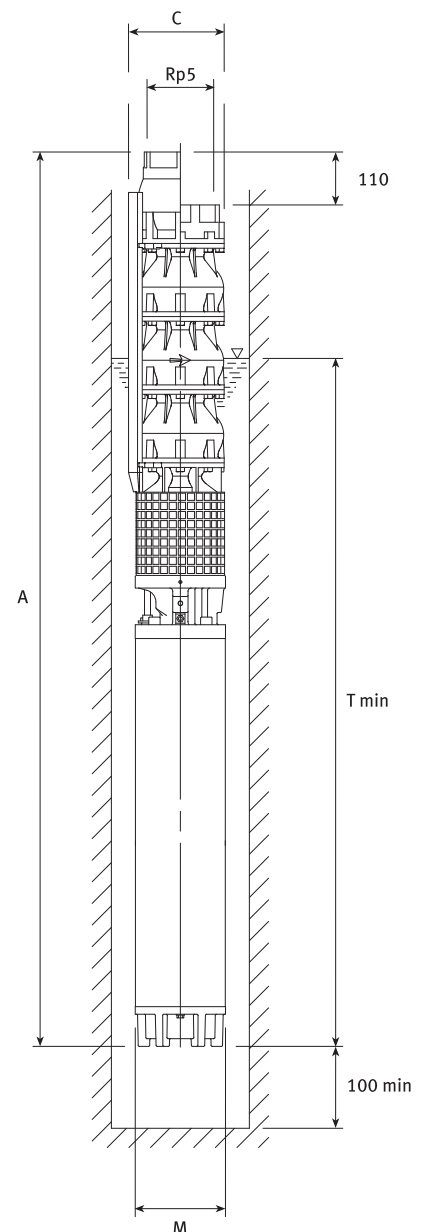

- 1. Max. diameter of the electropump including 2 motor cable outputs. In the case of 1 output cable C = 198 mm with **E6W** motor. C = 201,5 mm with **CP8** motor.
- 2. Tmin. OK for max. flow speed 4,2 m/s.
If this speed is higher contact the sales network.
- 3. Without cables.
- 4. If there is no non-return valve reduce elevation A to 110 mm and the weight to 4 Kg.

XS875 series from 7 to 18 stages

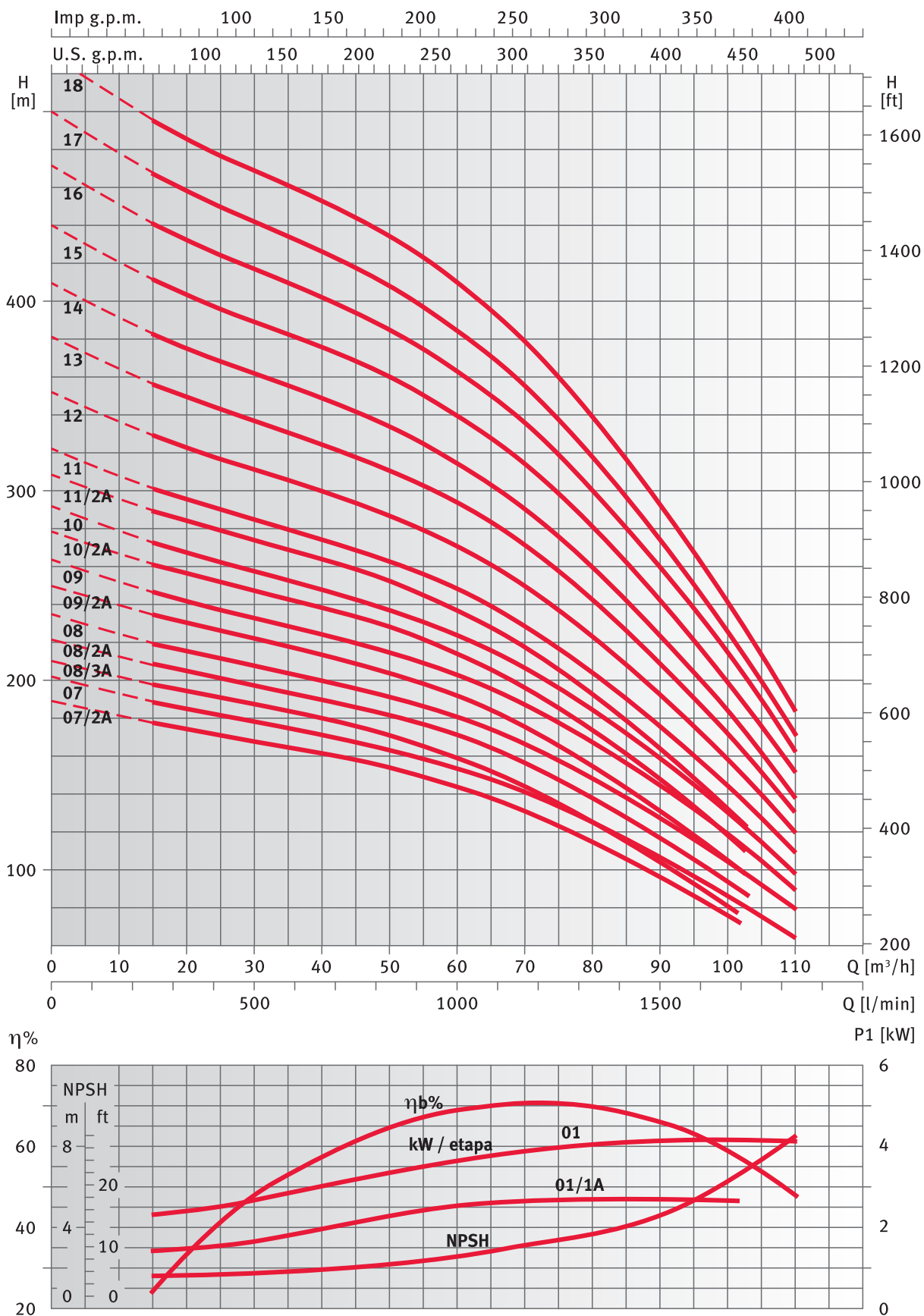

Load losses in the non-return valve included.
Performance valid for liquids with densities of $\rho = 1,0 \text{ kg/dm}^3$ and kinematic viscosity of $\nu = 1 \text{ mm}^2/\text{s}$.

XS895 series from 1 to 6 stages

PUMP TYPE	P2 kW	l/min m ³ /h	0	367	1000	1500	2150	2300
			0	22	60	90	129	138
XS895 01	7.5		28.5	27.7	25.3	21.6	12.3	9.8
XS895 02/2B	11		38.7	38.3	35.2	27.5		
XS895 02/2A	15		47.7	46.6	44	36.4	17.8	
XS895 02	15		57	55.4	50.7	43.2	24.6	19.5
XS895 03/2B	18.5		67.2	66.1	60.8	49.4		
XS895 03/1A	22		81.1	79	73	61.8	34	
XS895 03	30		86	83.8	77.3	66.4	39	30.4
XS895 04/2B	30		96	94.1	86.7	71.8		
XS895 04/2A	30		104.5	102	94.7	79.7	42.5	
XS895 04	30		113.8	110.7	101.4	86.5	49.3	39.2
XS895 05/3A	37		128	125	116.4	97.5	50.8	
XS895 05	37		141.9	138	126.4	107.5	60.9	48.7
XS895 06/3A	44		158.4	154.8	144.6	122.4	67.1	
XS895 06	44		172.6	168.1	154.9	132.8	77.7	60.5

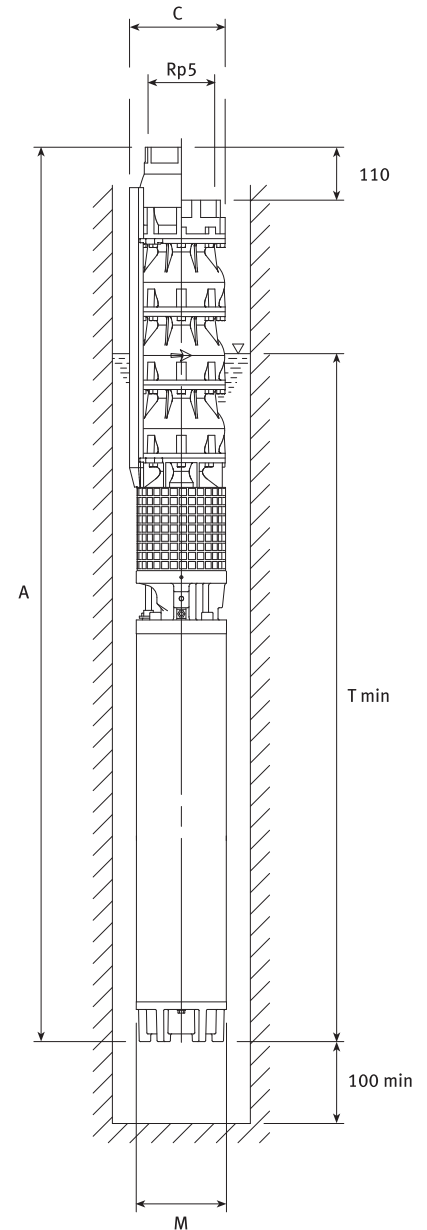

XS895 series dimensions and weights

PUMP TYPE	DIMENSIONS (mm)				WEIGHT
	A ⁽⁴⁾	C ⁽¹⁾	M	Tmin ⁽²⁾	kg ⁽³⁾
XS895 01-6	1237	200	140	1660	73
XS895 02/2B-6	1459	200	140	1730	89
XS895 02/2A-6	1514	200	140	1785	96
XS895 02-6	1514	200	140	1785	96
XS895 03/2B-6	1741	200	140	1860	112
XS895 03/1A-6	1801	200	140	1920	118
XS895 03-6	1931	200	140	2050	131
XS895 04/2B-6	2083	200	140	2050	140
XS895 04/2A-6	2083	200	140	2050	140
XS895 04-6	2083	200	140	2050	140
XS895 05/3A-6	2365	200	140	2180	162
XS895 05-6	2365	200	140	2180	162
XS895 06/3A-68	2532	203.3	192	2195	254
XS895 06-8	2532	203.3	192	2195	254

- 1. Max. diameter of the electropump including 2 motor cable outputs. In the case of 1 output cable C = 198 mm with **E6W** motor. C = 201,5 mm with **CP8** motor.
- 2. Tmin. OK for max. flow speed 4,2 m/s.
If this speed is higher contact the sales network.
- 3. Without cables.
- 4. If there is no non-return valve reduce elevation A to 110 mm and the weight to 4 Kg.

XS895 series from 1 to 6 stages

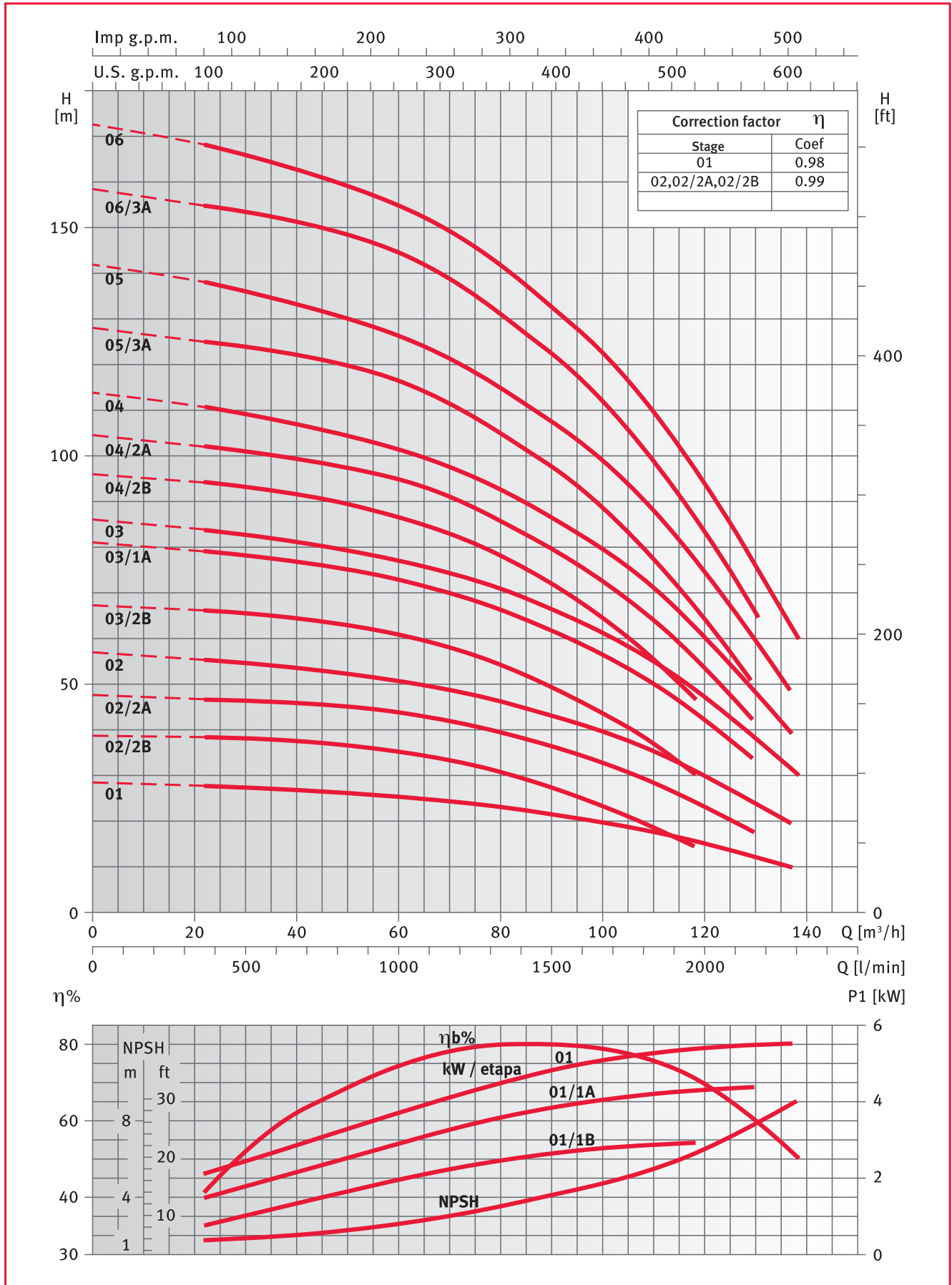

Load losses in the non-return valve ΔH_v are not included.
 $\Delta H_v = 0,0000533 \cdot Q^2$ Losses = 0,2 / 0,45 / 0,75 m at 60 / 90 / 120 m³/h
 Performance valid for liquids with densities of $\rho = 1,0 \text{ kg/dm}^3$ and kinematic viscosity of $\nu = 1 \text{ mm}^2/\text{s}$.

XS895 series from 7 to 18 stages

PUMP TYPE	P2 kW	l/min m ³ /h	0	367	1000	1500	2150	2300
			0	22	60	90	129	138
XS895 07/3A	52		186.5	182.1	169.6	144	79.8	
XS895 07	55		201.5	196.4	181.3	156.2	92.4	72.4
XS895 08/3A	59		215.7	210.6	196	166.7	93.3	
XS895 08	59		229.9	223.9	206.3	177.2	104	81.1
XS895 09/3A	66		244.4	238.6	221.9	188.9	106.2	
XS895 09	75		258.9	252.4	233	200.8	119	93.2
XS895 10/3A	75		272.9	266.3	247.3	210.9	Ç119.3	
XS895 10	75		287	279.6	257.6	221.5	130	101.4
XS895 11	92		316.3	308.2	284.6	245.2	145	113.4
XS895 12	92		346.3	337.6	311.5	268.1	158.8	124.4
XS895 13	110		374.9	365.6	338.1	291.9	174	137.5
XS895 14	110		403.1	393	363	312.8	185.4	145.2
XS895 15	129		434.2	423.5	391.4	337.7	201.8	159
XS895 16	129		462.6	451	416.2	358.6	213.2	169
XS895 17	129		490.9	478.4	440.9	379.4	224.2	175.5
XS895 18	150		520.2	507.1	468.5	404.2	241	189.3

XS895 series dimensions and weights

PUMP TYPE	DIMENSIONS (mm)				WEIGHT kg ⁽³⁾
	A ⁽⁴⁾	C ⁽¹⁾	M	Tmin ⁽²⁾	
XS895 07/3A-8	2774	203.3	192	2285	282
XS895 07-8	2814	203.3	192	2325	288
XS895 08/3A-8	3016	203.3	192	2375	308
XS895 08-8	3016	203.3	192	2375	308
XS895 09/3A-8	3258	203.3	192	2465	336
XS895 09-8	3348	203.3	192	2555	353
XS895 10/3A-8	3500	203.3	192	2555	362
XS895 10-8	3500	203.3	192	2555	362
XS895 11-8	3852	203.3	192	2755	409
XS895 12-8	4004	203.3	192	2755	418
XS895 13-10	4124	236	236	2702	538
XS895 14-10	4276	236	236	2702	548
XS895 15-10	4578	236	236	2852	604
XS895 16-10	4730	236	236	2852	613
XS895 17-10	4882	236	236	2852	622
XS895 18-10	5164	236	236	2852	671

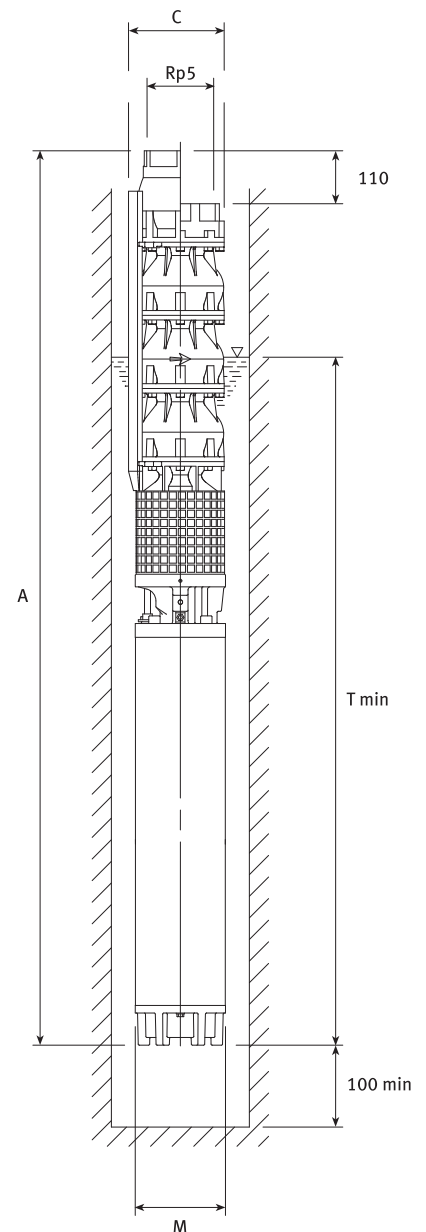

- 1. Max. diameter of the electropump including 2 motor cable outputs. In the case of 1 output cable. C = 201,5 mm with **CP8** motor. C = 236 mm with **CP10** motor.
- 2. Tmin. OK for max. flow speed 4,2 m/s.
If this speed is higher contact the sales network.
- 3. Without cables.
- 4. If there is no non-return valve reduce elevation A to 110 mm and the weight to 4 Kg.

XS895 series from 7 to 18 stages

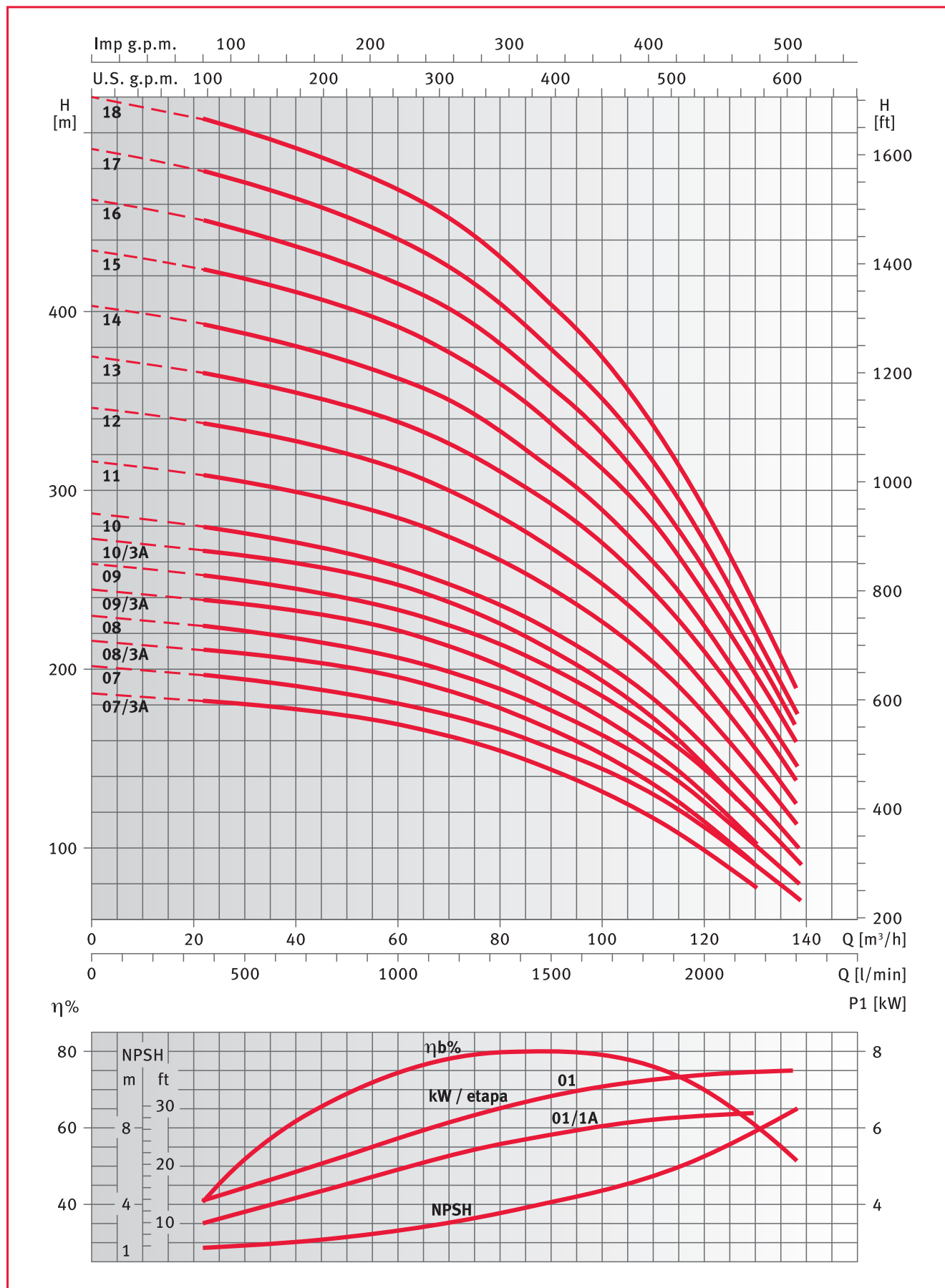

Load losses in the non-return valve ΔH_v are not included.
 $\Delta H_v = 0,0000533 \cdot Q^2$ Losses = 0,2 / 0,45 / 0,75 m at 60 / 90 / 120 m³/h
 Performance valid for liquids with densities of $\rho = 1,0 \text{ kg/dm}^3$ and kinematic viscosity of $\nu = 1 \text{ mm}^2/\text{s}$.

XS8125 series from 1 to 6 stages

PUMP TYPE	P2 kW	l/min m ³ /h	0	500	1333	2083	2800	3000
			0	30	80	125	168	180
XS8125 01	7.5		27.1	24.7	21	17.1	9.4	6.9
XS8125 02/2B	11		41.9	38.8	31.8	22.3		
XS8125 02/2A	15		48.3	44.6	37.5	28.9	13	
XS8125 02	15		54.3	49.5	42	34.1	18.8	13.7
XS8125 03/3A	18.5		71.9	66.2	55.5	42.6	19.3	
XS8125 03	22		81.7	74.6	63.4	51.5	28.7	20.7
XS8125 04/2B	30		97	89.2	74.8	57.5		
XS8125 04/2A	30		102.6	94.1	79.5	63.1	32.9	
XS8125 04	30		108.5	99	84.1	68.3	37.8	27.5
XS8125 05/3A	37		126.4	116	97.9	77.1	39.3	
XS8125 05	37		135.2	123.4	104.7	84.8	46.6	34.2
XS8125 06/3A	44		156.4	143.5	121.7	97.1	50.2	
XS8125 06	44		165.5	151.1	128.8	105	60	41.9

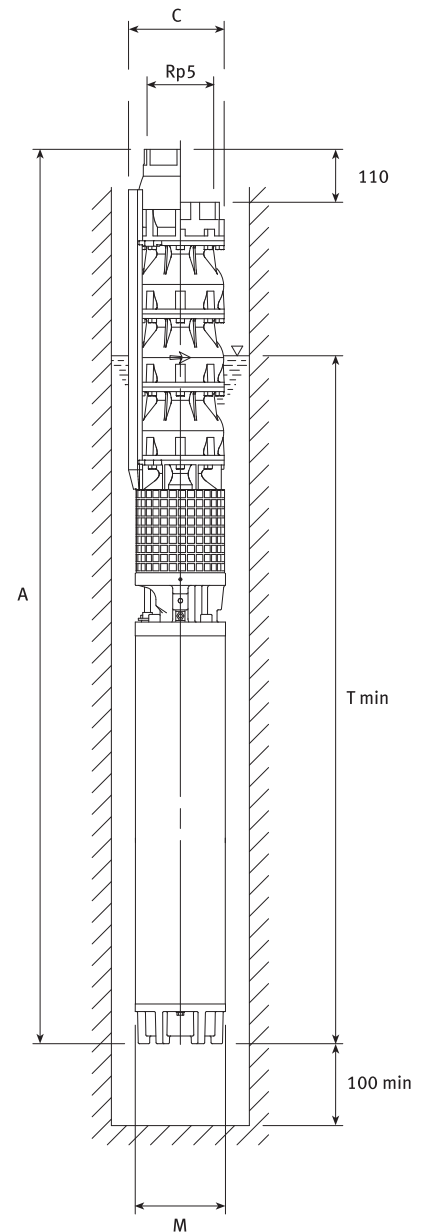

XS8125 series dimensions and weights

PUMP TYPE	DIMENSIONS (mm)				WEIGHT
	A ⁽⁴⁾	C ⁽¹⁾	M	Tmin ⁽²⁾	kg ⁽³⁾
XS8125 01-6	1237	200	140	1660	73
XS8125 02/2B-6	1459	200	140	1730	89
XS8125 02/2A-6	1514	200	140	1785	96
XS8125 02-6	1514	200	140	1785	96
XS8125 03/3A-6	1741	200	140	1860	112
XS8125 03-6	1801	200	140	1920	118
XS8125 04/2B-6	2083	200	140	2050	140
XS8125 04/2A-6	2083	200	140	2050	140
XS8125 04-6	2083	200	140	2050	140
XS8125 05/3A-6	2365	200	140	2180	162
XS8125 05-6	2365	200	140	2180	162
XS8125 06/3A-8	2532	203.3	192	2195	254
XS8125 06-8	2532	203.3	192	2195	254

- 1. Max. diameter of the electropump including 2 motor cable outputs. In the case of 1 output cable C = 198 mm with **E6W** motor. C = 201,5 mm with **CP8** motor.
- 2. Tmin. OK for max. flow speed 4,2 m/s.
If this speed is higher contact the sales network.
- 3. Without cables.
- 4. If there is no non-return valve reduce elevation A to 110 mm and the weight to 4 Kg.

XS8125 series from 1 to 6 stages

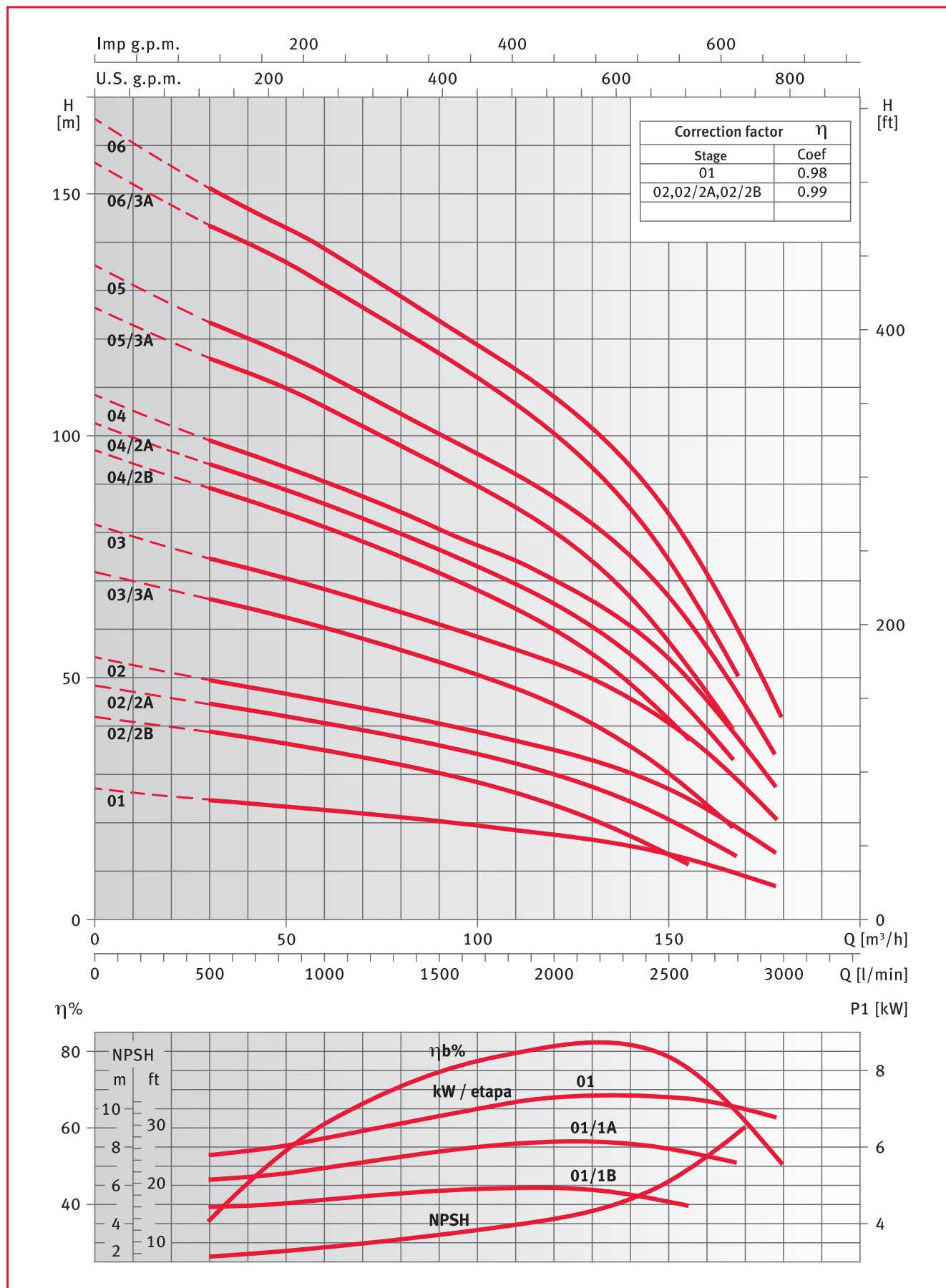

Load losses in the non-return valve ΔH_v are not included.
 $\Delta H_v = 0,0000533 \cdot Q^2$ Losses 0,35 / 0,75 / 1,35 m at 80 / 120 / 160 m³/h
 Performance valid for liquids with densities of $\rho = 1,0 \text{ kg/dm}^3$ and kinematic viscosity of $\nu = 1 \text{ mm}^2/\text{s}$.

XS8125 series from 7 to 18 stages

PUMP TYPE	P2 kW	l/min m ³ /h	0	500	1333	2083	2800	3000
			0	30	80	125	168	180
XS8125 01	7.5		27.1	24.7	21	17.1	9.4	6.9
XS8125 02/2B	11		41.9	38.8	31.8	22.3		
XS8125 02/2A	15		48.3	44.6	37.5	28.9	13	
XS8125 02	15		54.3	49.5	42	34.1	18.8	13.7
XS8125 03/3A	18.5		71.9	66.2	55.5	42.6	19.3	
XS8125 03	22		81.7	74.6	63.4	51.5	28.7	20.7
XS8125 04/2B	30		97	89.2	74.8	57.5		
XS8125 04/2A	30		102.6	94.1	79.5	63.1	32.9	
XS8125 04	30		108.5	99	84.1	68.3	37.8	27.5
XS8125 05/3A	37		126.4	116	97.9	77.1	39.3	
XS8125 05	37		135.2	123.4	104.7	84.8	46.6	34.2
XS8125 06/3A	44		156.4	143.5	121.7	97.1	50.2	
XS8125 06	44		165.5	151.1	128.8	105	60	41.9

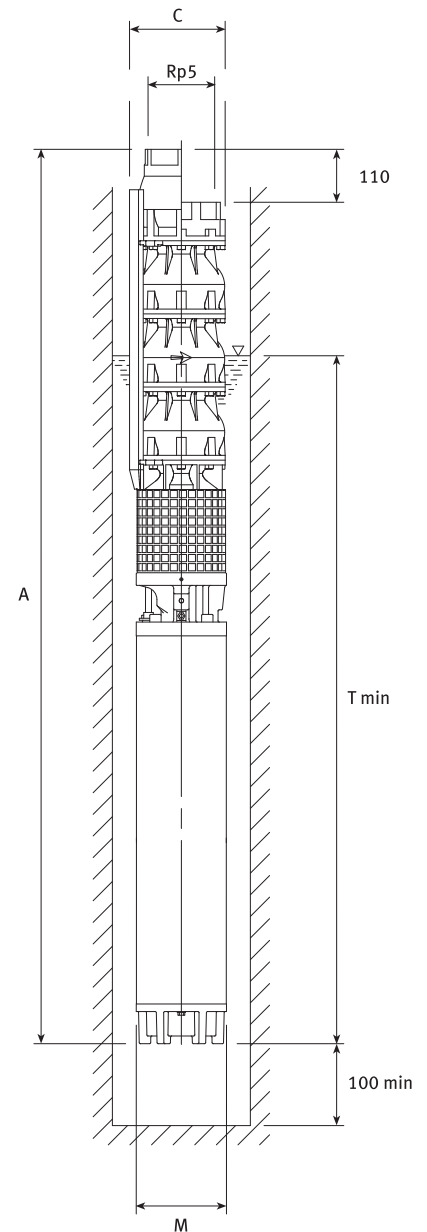

XS8125 series dimensions and weights

PUMP TYPE	DIMENSIONS (mm)				WEIGHT
	A ⁽⁴⁾	C ⁽¹⁾	M	Tmin ⁽²⁾	kg ⁽³⁾
XS8125 01-6	1237	200	140	1660	73
XS8125 02/2B-6	1459	200	140	1730	89
XS8125 02/2A-6	1514	200	140	1785	96
XS8125 02-6	1514	200	140	1785	96
XS8125 03/3A-6	1741	200	140	1860	112
XS8125 03-6	1801	200	140	1920	118
XS8125 04/2B-6	2083	200	140	2050	140
XS8125 04/2A-6	2083	200	140	2050	140
XS8125 04-6	2083	200	140	2050	140
XS8125 05/3A-6	2365	200	140	2180	162
XS8125 05-6	2365	200	140	2180	162
XS8125 06/3A-8	2532	203.3	192	2195	254
XS8125 06-8	2532	203.3	192	2195	254

- 1. Max. diameter of the electropump including 2 motor cable outputs. In the case of 1 output cable. C = 201,5 mm with **CP8** motor. C = 236 mm with **CP10** motor.
- 2. T min. OK for max. flow speed 4,2 m/s.
If this speed is higher contact the sales network.
- 3. Without cables.
- 4. If there is no non-return valve reduce elevation A to 110 mm and the weight to 4 Kg.

XS8125 series from 7 to 18 stages

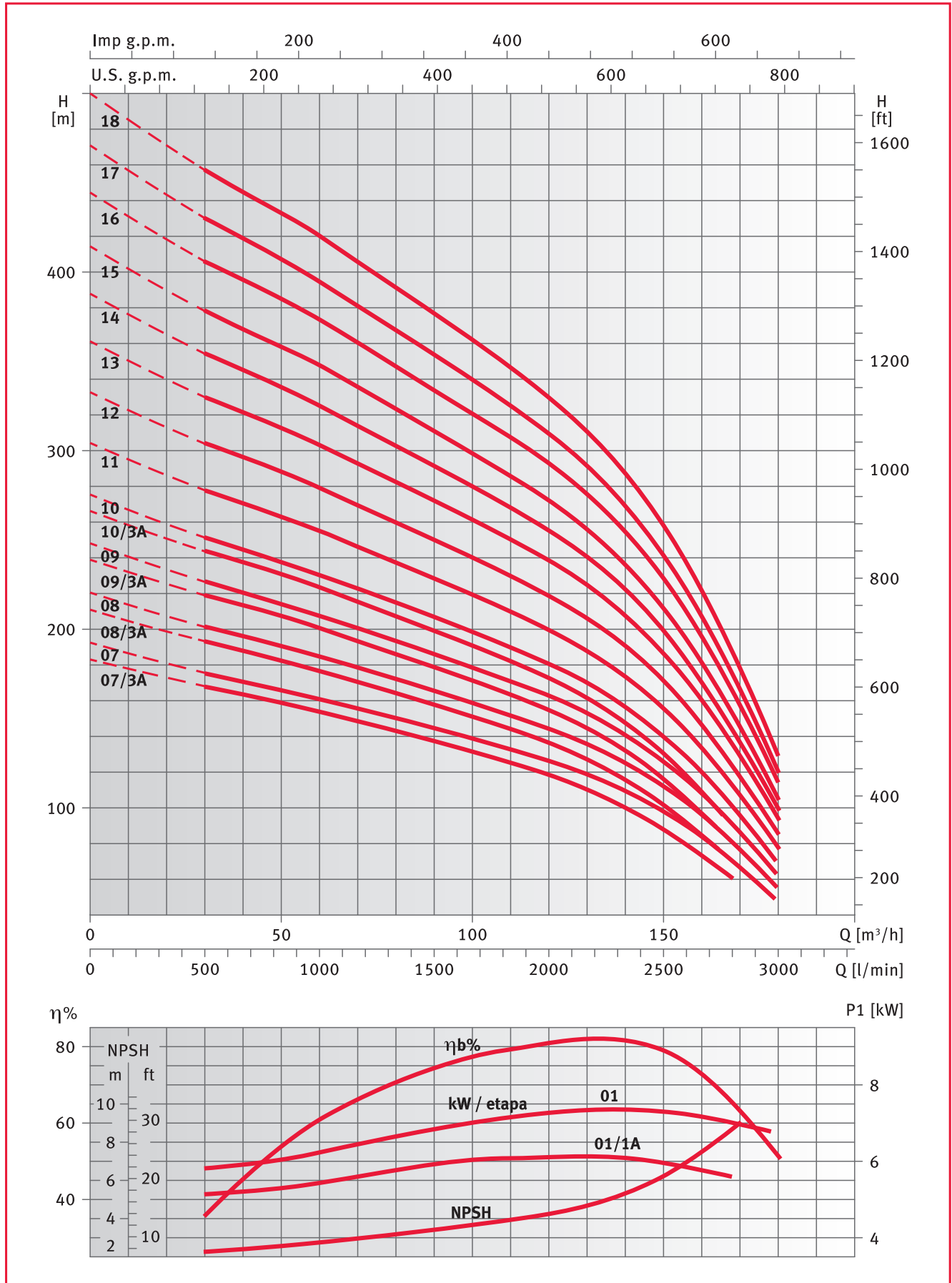

Load losses in the non-return valve ΔH_v are not included.
 $\Delta H_v = 0,0000533 \cdot Q^2$ Losses 0,35 / 0,75 / 1,35 m at 80 / 120 / 160 m³/h
 Performance valid for liquids with densities of $\rho = 1,0 \text{ kg/dm}^3$ and kinematic viscosity of $\nu = 1 \text{ mm}^2/\text{s}$.

XS855 series

PUMP TYPE	MAX. POWER ABSORBED BY PUMP at 2900 min ⁻¹ (kW)	DIMENSIONS (mm)			WEIGHT kg ⁽³⁾
		L ⁽³⁾	I	Umin ⁽²⁾	
XS855 01	4.6	325	235	1000	26.6
XS855 02/2A	6.4	460	235	1000	35.2
XS855 02/1A	7.7	460	235	1000	35.2
XS855 02	9	460	235	1000	35.2
XS855 03/2A	10.8	595	235	1000	43.9
XS855 03	13.3	595	235	1000	43.9
XS855 04/2A	15.1	730	235	1000	52.5
XS855 04	17.6	730	235	1000	52.5
XS855 05/3A	18.3	865	235	1000	61.2
XS855 05/2A	20.8	865	235	1000	61.2
XS855 05	22	865	235	1000	61.2
XS855 06/2A	23.9	1000	235	1000	69.8
XS855 06	26.4	1000	235	1000	69.8
XS855 07/2A	28.3	1135	235	1000	78.5
XS855 04	30.8	1135	235	1000	78.5
XS855 08/2A	32.7	1270	235	1000	87.1
XS855 08	35.2	1270	235	1000	87.1
XS855 09/2A	37.1	1405	235	1000	95.8
XS855 09	39.6	1405	235	1000	95.1
XS855 10/2A	41.5	1540	235	1000	103.8
XS855 10	44	1540	235	1000	103.8
XS855 11/2A	45.9	1675	235	1000	112.4
XS855 11	48.4	1675	235	1000	112.4
XS855 12	52.8	1810	235	1000	121.1
XS855 13	57.2	1945	235	1000	129.7
XS855 14	61.6	2080	235	1000	138.4
XS855 15	66	2215	235	1000	147
XS855 16	70.4	2350	235	1000	155.7
XS855 17	74.8	2485	235	1000	164.3
XS855 18	79.2	2620	235	1000	173
XS855 19	83.6	2755	235	1000	181.6

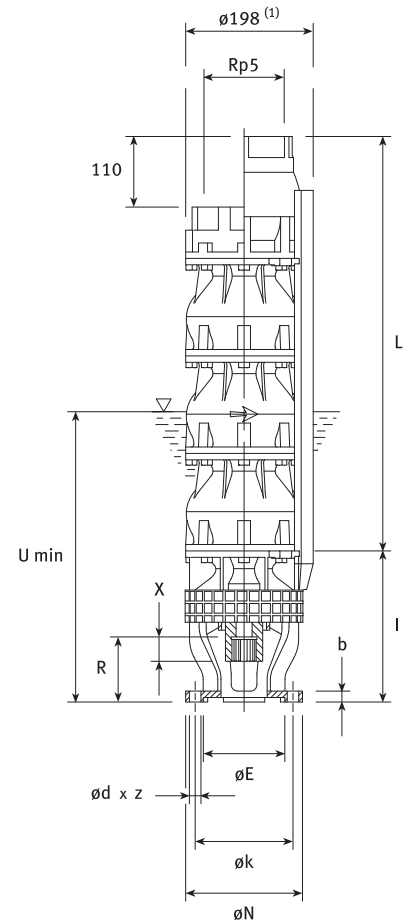

XS855 series 6" and 8" motor coupling

MOTOR	DIMENSIONS (mm)							
	N	k	d	z	b	E H ⁷	R	X
6" (NEMA)	182	111	13.5	4	17	76.16	73	24
8" (NEMA)	182	152.4	18	4	17	127	101.3	40

- 1. Max. pump diameter including 1 motor cable output.
- 2. U min. OK for max. flow speed 4,2 m/s.
If this speed is higher contact the sales network.
- 3. In the absence of a non-return valve reduce elevation L to 110 mm and the weight to 4 Kg.

XS875 series

PUMP TYPE	MAX POWER ABSORBED BY PUMP at 2900 min ⁻¹ (kW)	DIMENSIONS (mm)			WEIGHT kg ⁽³⁾
		L ⁽³⁾	I	Umin ⁽²⁾	
XS875 01	5.3	342	235	1000	26.9
XS875 02/2A	7.6	494	235	1000	36.2
XS875 02/1A	9	494	235	1000	36.2
XS875 02	10.5	494	235	1000	36.2
XS875 03/3A	11.3	646	235	1000	45.4
XS875 03/2A	12.7	646	235	1000	45.4
XS875 03/1A	14.2	646	235	1000	45.4
XS875 03	15.6	646	235	1000	45.4
XS875 04/2A	17.7	798	235	1000	54.6
XS875 04	20.6	798	235	1000	54.6
XS875 05/3A	21.5	950	235	1000	63.9
XS875 05/2A	22.9	950	235	1000	63.9
XS875 05	25.8	950	235	1000	63.9
XS875 06/2A	28	1102	235	1000	73.1
XS875 06/1A	29.5	1102	235	1000	73.1
XS875 06	30.9	1102	235	1000	73.1
XS875 07/2A	33.2	1254	235	1000	82.3
XS875 07	36.1	1254	235	1000	82.3
XS875 08/3A	36.9	1406	235	1000	91.5
XS875 08/2A	38.3	1406	235	1000	90.9
XS875 08	41.2	1406	235	1000	90.9
XS875 09/2A	43.5	1558	235	1000	100.1
XS875 09	46.4	1558	235	1000	100.1
XS875 10/2A	48.6	1710	235	1000	109.4
XS875 10	51.5	1710	235	1000	109.4
XS875 11/2A	53.8	1862	235	1000	118.6
XS875 11	56.7	1862	235	1000	118.6
XS875 12	61.8	2014	235	1000	127.8
XS875 13	67	2166	235	1000	137
XS875 14	72.1	2318	235	1000	146.3
XS875 15	77.3	2470	235	1000	155.5
XS875 16	82.4	2622	235	1000	164.7
XS875 17	87.6	2774	235	1000	174
XS875 18	92.7	2926	256	1000	183.2

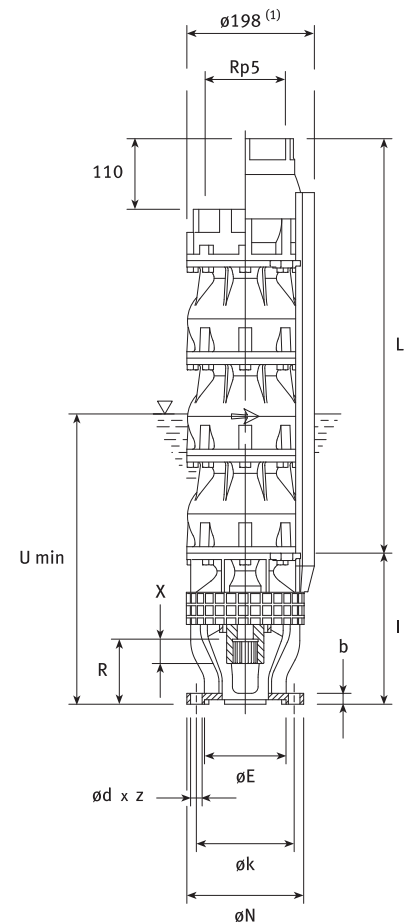

XS875 series 6", 8" and 10" motor coupling

MOTOR	DIMENSIONS (mm)							
	N	k	d	z	b	E ^{H7}	R	X
6" (NEMA)	182	111	13.5	4	17	76.16	73	24
8" (NEMA)	182	152.4	18	4	17	127	101.3	40
10"	232	190.5	M16	4	21	127	101.3	84

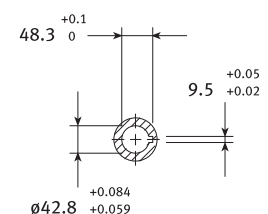

- 1. Max. pump diameter including 1 motor cable output.
- 2. U min. OK for max. flow speed 4,2 m/s.
If this speed is higher contact the sales network.
- 3. In the absence of an non-return valve reduce elevation L to 110 mm and the weight to 4 Kg.

XS895 series

PUMP TYPE	MAX POWER ABSORBED BY PUMP at 2900 min ⁻¹ (kW)	DIMENSIONS (mm)			WEIGHT kg ⁽³⁾
		L ⁽³⁾	I	Umin ⁽²⁾	
XS895 01	7.7	342	235	1000	26.9
XS895 02/2B	10	494	235	1000	36.2
XS895 02/2A	12.8	494	235	1000	36.2
XS895 02	15.2	494	235	1000	36.2
XS895 03/2B	17.4	646	235	1000	45.4
XS895 03/1A	21.4	646	235	1000	45.4
XS895 03	22.5	646	235	1000	45.4
XS895 04/2B	24.6	798	235	1000	54.6
XS895 04/2A	27.4	798	235	1000	54.6
XS895 04	29.8	798	235	1000	54.6
XS895 05/3A	33.7	950	235	1000	63.9
XS895 05	37.2	950	235	1000	63.9
XS895 06/3A	41.1	1102	235	1000	73.1
XS895 06	44.6	1102	235	1000	73.1
XS895 07/3A	48.6	1254	235	1000	81.7
XS895 07	52.1	1254	235	1000	81.7
XS895 08/3A	56	1406	235	1000	90.9
XS895 08	59.5	1406	235	1000	90.9
XS895 09/3A	63.5	1558	235	1000	100.1
XS895 09	67	1558	235	1000	100.1
XS895 10/3A	70.9	1710	235	1000	109.4
XS895 10	74.4	1710	235	1000	109.4
XS895 11	81.8	1862	235	1000	118.6
XS895 12	89.3	2014	235	1000	127.8
XS895 13	96.7	2166	256	1000	137
XS895 14	104.2	2318	256	1000	146.3
XS895 15	111.6	2470	256	1000	155.5
XS895 16	119	2622	256	1000	164.7
XS895 17	126.5	2774	256	1000	174
XS895 18	133.9	2926	256	1000	183.2

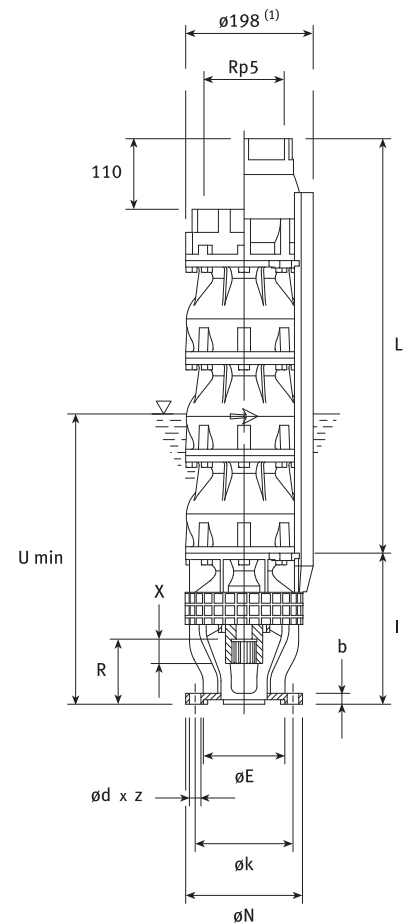

XS895 series 6", 8" and 10" motor coupling

MOTOR	DIMENSIONS (mm)							
	N	k	d	z	b	E H7	R	X
6" (NEMA)	182	111	13.5	4	17	76.16	73	24
8" (NEMA)	182	152.4	18	4	17	127	101.3	40
10"	232	190.5	M16	4	21	127	101.3	84

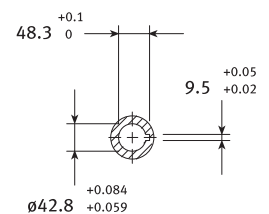

- ⇒ 1. Max. pump diameter including 1 motor cable output.
- ⇒ 2. U min. OK for max. flow speed 4,2 m/s.
If this speed is higher contact the sales network.
- ⇒ 3. In the absence of an non-return valve reduce elevation L to 110 mm and the weight to 4 Kg.

XS8125 series

PUMP TYPE	MAX POWER ABSORBED BY PUMP at 2900 min ⁻¹ (kW)	DIMENSIONS (mm)			WEIGHT kg ⁽³⁾
		L ⁽³⁾	I	Umin ⁽²⁾	
XS8125 01	7.5	342	235	1000	26.9
XS8125 02/2B	10	494	235	1000	36.2
XS8125 02/2A	12.2	494	235	1000	36.2
XS8125 02	14.8	494	235	1000	36.2
XS8125 03/3A	18.1	646	235	1000	45.4
XS8125 03	22	646	235	1000	45.4
XS8125 04/2B	24.3	798	235	1000	54.6
XS8125 04/2A	26.5	798	235	1000	54.6
XS8125 04	29	798	235	1000	54.6
XS8125 05/3A	32.5	950	235	1000	63.9
XS8125 05	36.3	950	235	1000	63.9
XS8125 09/3A	39.7	1102	235	1000	73.1
XS8125 06	43.5	1102	235	1000	73.1
XS8125 07/3A	47	1254	235	1000	81.7
XS8125 07	50.8	1254	235	1000	81.7
XS8125 08/3A	54.2	1406	235	1000	90.9
XS8125 08	58	1406	235	1000	90.9
XS8125 09/3A	61.5	1558	235	1000	100.1
XS8125 09	65.3	1558	235	1000	100.1
XS8125 10/3A	68.7	1710	235	1000	109.4
XS8125 10	72.5	1710	235	1000	109.4
XS8125 11	79.8	1862	235	1000	118.6
XS8125 12	87	2014	235	1000	127.8
XS8125 13	94.3	2166	256	1000	137
XS8125 14	101.5	2318	256	1000	146.3
XS8125 15	108.8	2470	256	1000	155.5
XS8125 16	116	2622	256	1000	164.7
XS8125 17	123.3	2774	256	1000	174
XS8125 18	130.5	2926	256	1000	183.2

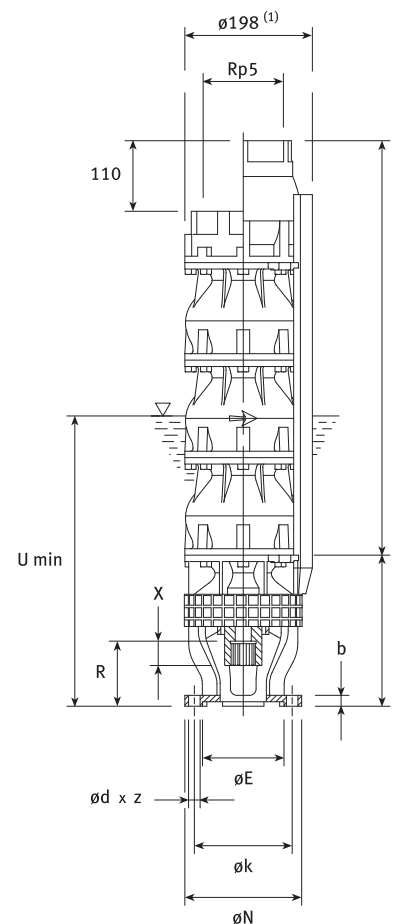

XS8125 series 6", 8" and 10" motor coupling

MOTOR	DIMENSIONS (mm)							
	N	k	d	z	b	E ^{H7}	R	X
6" (NEMA)	182	111	13.5	4	17	76.16	73	24
8" (NEMA)	182	152.4	18	4	17	127	101.3	40
10"	232	190.5	M16	4	21	127	101.3	84

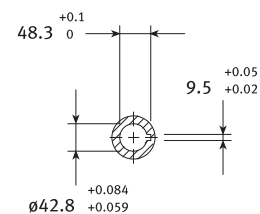

- 1. Max. pump diameter including 1 motor cable output.
- 2. U min. OK for max. flow speed 4,2 m/s.
If this speed is higher contact the sales network.
- 3. In the absence of an non-return valve reduce elevation L to 110 mm and the weight to 4 Kg.

XS8 Series

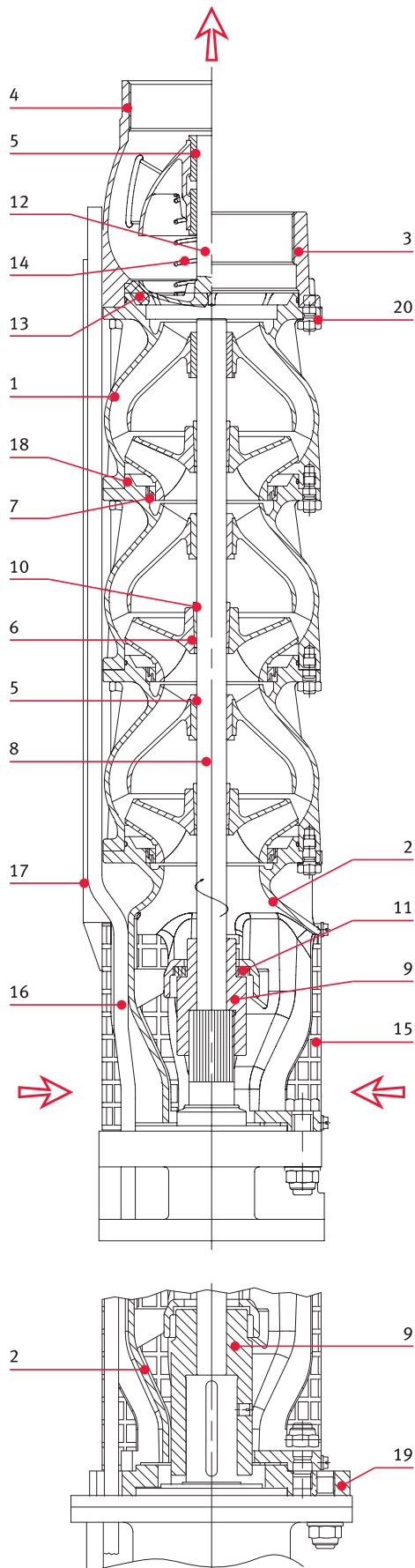

REF.	DESCRIPTION
1	Stages body
2	Lower suction support
3	Impeller body
4	Valve body
5	Bushing bearing
6	Impeller
7	Friction ring
8	Shaft
9	Joint
10	Impeller fastening cone
11	Shaft box support
12	Non-return valve
13	Valve seating
14	Valve spring
15	Suction filter
16	Motor cable
17	Cable protection
18	OR joint
19	Adaptor for 10" motor
20	Adjustment plate

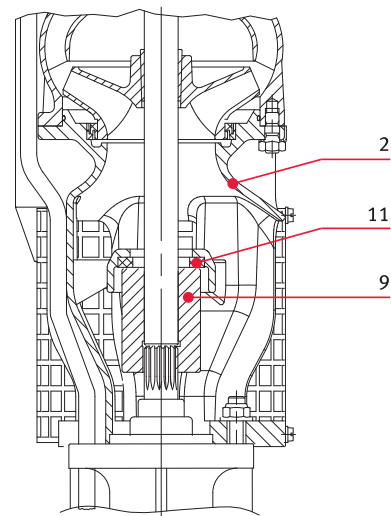

XS8 Series

6", 8" and 10" submersible motors E6W, CP8 and CP10

50 Hz

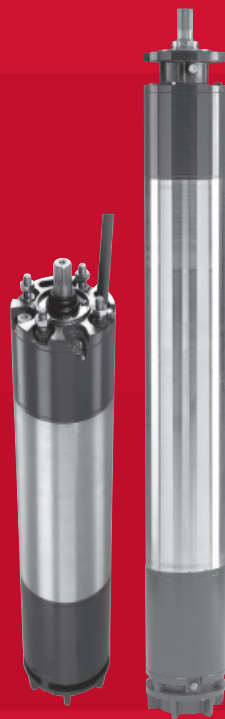

Description

- Motors immersed in water.
- The choice of construction materials guarantees optimum operating performance, superior quality, reliability and easy installation.

Electrical and motor specifications

- Outer casing made of stainless steel.
- Projecting shaft element and coupling elevations based on the NEMA guidelines.
- Rewindable stator with PVC -insulated rewinding thread.
- Y insulation class motor.
- Protection class: IP68.
- Compensation bellows for expanding of liquid inside.
- Axial load supported by Kingsbury type segmented bearing.
- Mechanical seal with anti-sand protection.
- Maximum immersion depth: 350 m.
- Maximum number of start-ups per hour distributed on a fairly basis: 15.
- Maximum deviation allowed for line voltage compared to nominal voltage: $\pm 10\%$.
- Maximum water temperature: 25°C.
- Max. temperature is taken for motors operating in a facility able to guarantee a water flow around the motor casing of at least 0,2 m/s (0,5 m/s at 37 kW).
- Axial thrust:
 - 16000 N from 4 at 22 kW;
 - 30000 N from 26 at 37 kW.
- Power cable for use in contact with drinking water.
 - Versions:
 - Three-phase: from 4 at 37 kW 380-415 V, 50 Hz.
- Motors fitted with double cable output for star-triangle start-up, on request.
- Horizontal operation in all versions, provided the axial thrust generated by the impellers always acts in the pump to motor direction.
- Screws included.

Executions on request

- Mechanical seal made of silica carbide.
- 4 pole motors.
- Special voltages.
- Wound for high temperatures.
- Applications with inverter.
- PT 100 temperature sensor.



Identification data

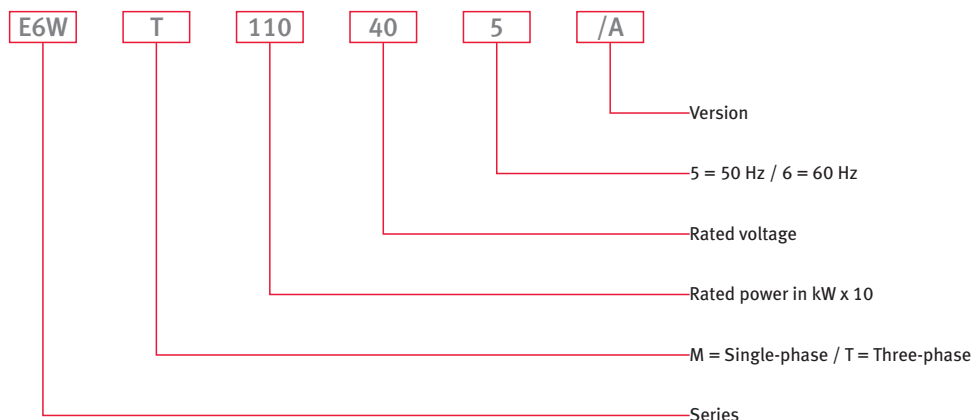

EXAMPLE: E6W110T405/A
 E6W motor; Nominal power 11 kW. Three-phase; Nominal voltage 400 V. 50 Hz. Version /A

E6W series motors dimensions and weights

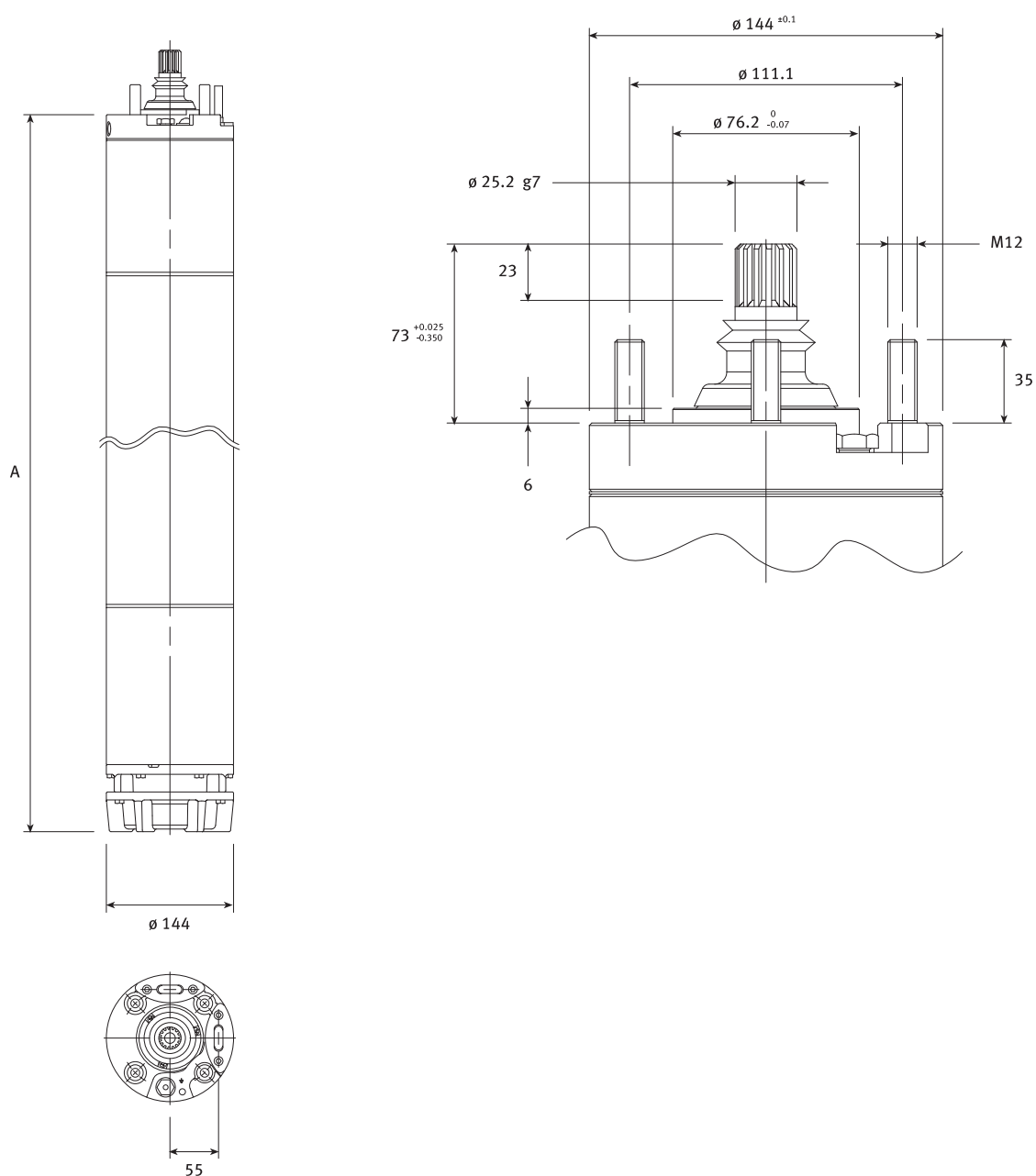

MOTOR TYPE	P2		DIMENSIONS (mm) L	WEIGHTS kg
	kW	HP		
E6WT 40-405	4	5.5	583	38
E6WT 55-405	5.5	7.5	613	42
E6WT 75-405	7.5	10	653	46
E6WT 93-405	9.3	12.5	683	50
E6WT 110-405	11	15	723	54
E6WT 130-405	13	17.5	763	58
E6WT 150-405	15	20	833	66
E6WT 185-405	18.5	25	903	74
E6WT 220-405	22	30	943	77
E6WT 260-405	26	35	1071	86
E6WT 300-405	30	40	1151	94
E6WT 370-405	37	50	1301	108

E6W series three-phase motors

MOTOR TYPE	P2		RATED VOLTAGE	OPERATING CHARACTERISTICS				DIRECT START-UP		MAX. WATER TEMPERATURE °C	TYPE OF CABLE		
				THREE-PHASE	kW	HP	V	RATED CURRENT A	rpm		η %	cosφ	Ts/Tn*
	DOL	Y/D											
E6WT 40-405	4	5.5	380	9.62	2845	69.5	0.91	0.96	3.64	25	4		4
			415	8.94	2880	72.2	0.86	1.15	4.27				
E6WT 55-405	5.5	7.5	380	12.7	2850	74	0.89	1.28	4.27	25	4	4	4
			415	12.3	2885	74.7	0.83	1.54	4.82				
E6WT 75-405	7.5	10	380	17.1	2830	74.4	0.9	1.18	4.07	25	4	4	4
			415	16.4	2865	75.7	0.84	1.43	4.65				
E6WT 93-405	9.3	12.5	380	20.5	2835	76.6	0.89	1.51	4.57	25	4	4	4
			415	19.8	2870	77.6	0.83	1.82	5.16				
E6WT 110-405	11	15	380	24.8	2825	76.3	0.89	1.36	4.27	25	4	4	4
			415	24	2860	77.4	0.82	1.64	4.81				
E6WT 130-405	13	17.5	380	28.7	2820	76.6	0.9	1.37	4.38	25	4	4	4
			415	27.5	2860	77.9	0.84	1.66	4.99				
E6WT 150-405	15	20	380	32.4	2830	76.1	0.89	1.62	4.83	25	4	4	4
			415	31.1	2865	80.3	0.84	1.96	5.48				
E6WT 185-405	18.5	25	380	40	2835	80.3	0.87	1.8	5.10	25	6	4	4
			415	39.6	2865	80.4	0.81	2.17	5.63				
E6WT 220-405	22	30	380	48.5	2835	78.7	0.88	1.05	4.59	25	6	4	4
			415	45.4	2875	81.8	0.82	1.26	5.3				
E6WT 260-405	26	35	380	56.2	2865	80.2	0.88	1.03	4.57	25	6	4	4
			415	53.4	2890	81.9	0.83	1.24	5.25				
E6WT 300-405	30	40	380	64.7	2855	80.5	0.88	1.08	4.59	25	10	4	4
			415	61.4	2885	82.1	0.83	1.3	5.28				
E6WT 370-405	37	50	380	81.7	2840	78.6	0.88	1	4.24	20	10	4	4
			415	78.8	2875	79.8	0.82	1.2	4.81				

Description

- Asynchronous, three-phase motor immersed in water, with rotor in short circuit and wound with special water-repellent thread.
- The choice of the component materials guarantees optimum operating performance, reliability and ease of installation.

Electrical and motor specifications

- Projecting shaft element and coupling elevations based on the NEMA guidelines.
- Rewindable stator with PVC insulation.
- Protection class: IP68.
- Filling liquid.
- The motors are filled with water and 15% of non-toxic anti-freeze liquid. In addition to having rust suppressing properties, the liquid improves lubrication and protects the motor at low temperatures.
- Large compensation bellows for expansion of the liquid inside. The motor also has a discharge valve allowing liquid to exit in the event of an abnormal increase in temperature.
- Axial load supported by oscillating segmented bearing.
- To prevent the exchange of fluids between the exterior and interior of the motor, all standard motors have two plugs placed opposite each other.
- Motors with mechanical seals available on request.
- Maximum immersion depth:
 - 40 m for standard motors (plug for shafts),
 - 350 m with motors on request (with mechanical seals).
- Maximum number of start-ups per hour distributed on a fair basis: 10 start-ups/h.
- Maximum deviation allowed for line voltage with respect to rated voltage (400V): +6%-10%.
- Axial thrust supported 50.000 N.
- Three-phase versions available **CP8** 30 kW at 92 kW 400V, and on request for other voltages.
- The rewinding thread is made of PVC.
- The motors are supplied with three 5 m pieces of single-pole, H07BBF type cable, with a circular cross-section.
- Room temperature: 25°C, the motors should operate with a water flow around their frameworks of at least 0,20 m/s.

Executions on request

- 4 pole motors.
- Special voltages up to 1000 V.
- Horizontal installation.
- Applications with inverter.
- Wound for high temperatures.
- Different materials.

Accessories

- Panels.
- Descending cables.



CP8 series motors dimensions and weights

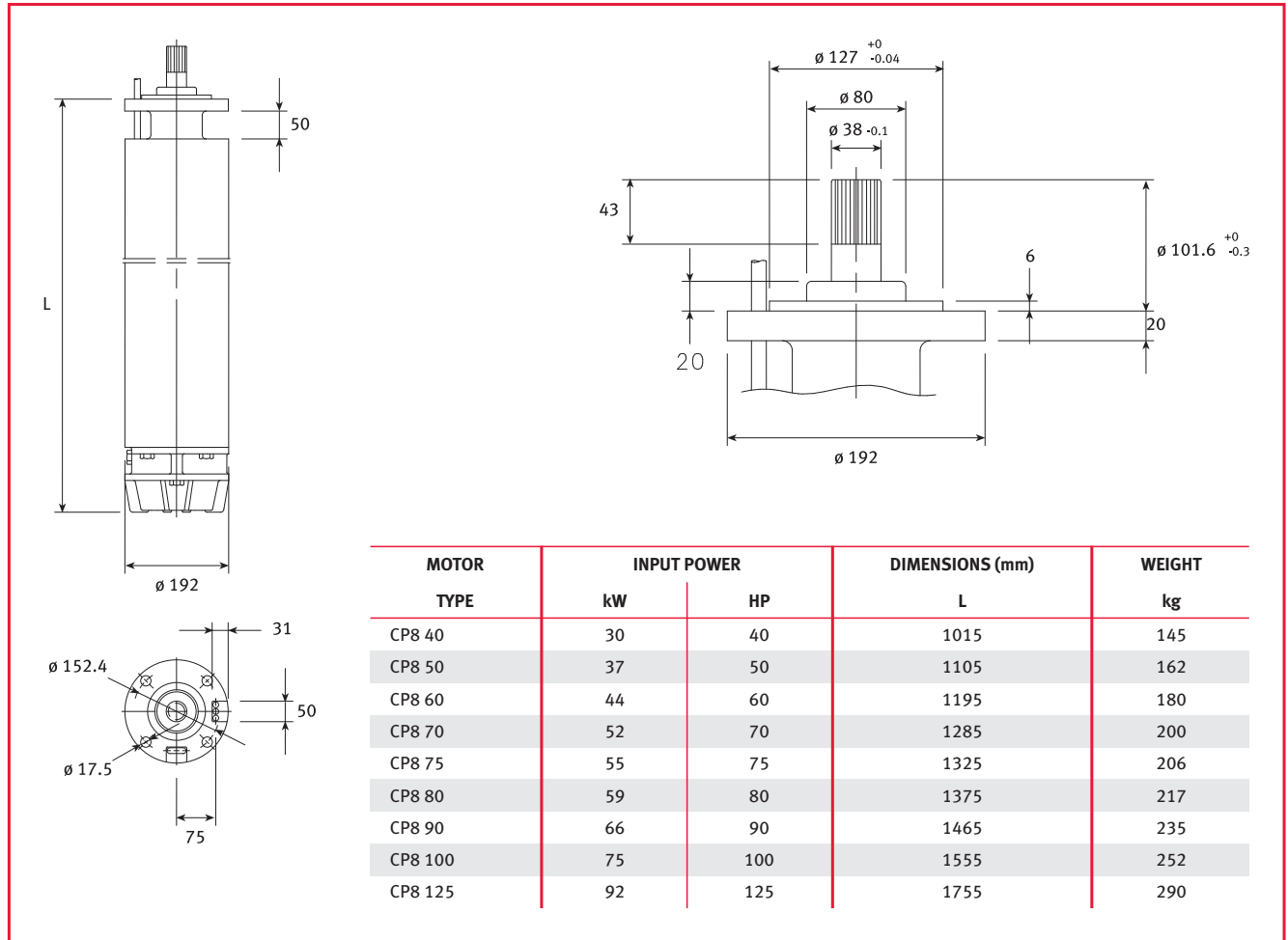

CP8 series motors operating characteristics 50 Hz

MOTOR TYPE	P2		RATED VOLTAGE	OPERATING CHARACTERISTICS				DIRECT START-UP		MAX. WATER TEMPERATURE	TYPE OF CABLE	
	kW	HP		RATED CURRENT	rpm	η %	cos ϕ	Ca/Cn	Ia/In		Ncxsez. (mm ²)	L(m)
TRIFÁSICO	kW	HP	V	A	rpm	η %	cos ϕ	Ca/Cn	Ia/In	°C	Ncxsez. (mm ²)	L(m)
CP8 40	30	40	380	65	2905	83	0.85	1.2	4.67	25	3x10	5
			415	59	2900	83	0.84	1.09	4.7			
CP8 50	37	50	380	82.5	2860	82	0.85	1.16	4.62	25	3x10	5
			415	76	2860	82	0.85	1.17	4.64			
CP8 60	44	60	380	94	2870	84	0.86	0.95	4.10	25	3x16	5
			415	85	2870	85	0.86	0.99	4.23			
CP8 70	52	70	380	112	2865	82	0.85	1.14	5.83	25	3x16	5
			415	104	2865	82.5	0.85	1.16	5.8			
CP8 75	55	75	380	118	2850	82	0.86	1.26	4.9	25	3x16	5
			415	110	2850	82.5	0.86	1.27	4.84			
CP8 80	59	80	380	125	2875	84	0.86	1.21	4.55	25	3x16	5
			415	115	2870	83.5	0.85	1.20	4.51			
CP8 90	66	90	380	141	2870	84	0.86	1.08	4.6	25	3x16	5
			415	130	2870	84	0.85	1.16	4.74			
CP8 100	75	100	380	156	2875	83	0.86	1.03	4.61	25	3x25	5
			415	144	2880	83	0.85	1.10	4.71			
CP8 125	92	125	380	192	2885	85	0.86	0.93	4.24	25	3x35	5
			415	176	2885	84.5	0.85	0.97	4.32			

Description

- Asynchronous, three-phase motor immersed in water, with rotor in short circuit and wound with special water-repellent thread.
- The choice of the component materials guarantees optimum operating performance, reliability and ease of installation.

Electrical and motor specifications

- Rewindable stator with PVC insulation.
- Protection class IP58.
- Filling liquid.
- The motors are filled with water and 15% of non-toxic anti-freeze liquid. In addition to having rust suppressing properties, the liquid improves lubrication and protects the motor at low temperatures.
- Large compensation bellows for expansion of the liquid inside. The motor also has a discharge valve allowing liquid to exit in the event of an abnormal increase in temperature.
- Axial load supported by oscillating segmented bearings.
- To prevent the exchange of fluids between the exterior and interior of the motor, all standard motors have two plugs placed opposite each other.
- Motors with mechanical seals available on request.
- Maximum immersion depth:
 - 40 m for standard motors (plugs for shafts),
 - 350 m with motors on request (with mechanical seals).
- Maximum number of start-ups per hour distributed on a fair basis: 8 start-ups/h.
- Maximum deviation allowed for line voltage with respect to rated voltage (400V): +6%-10%.
- Axial thrust supported 65.000 N.
- Version available:
 - Three-phase **CP10** 92 kW at 150 Kw 400 V and on request for different voltages.
- The rewinding thread is made of PVC.
- The motors are supplied with three 5 m pieces of single-pole, H07BBF type cable, with a circular cross-section.
- Room temperature: 25°C, the motors should operate with a water flow around their frameworks of at least 0,20 m/s.

Executions on request

- 4 pole motors.
- Special voltages up to 1000 V.
- Horizontal installation.
- Applications with inverter.
- Wound for high temperatures.
- Different materials.

Accessories

- Panels.
- Descending cables.



CP10 motors dimensions and weights

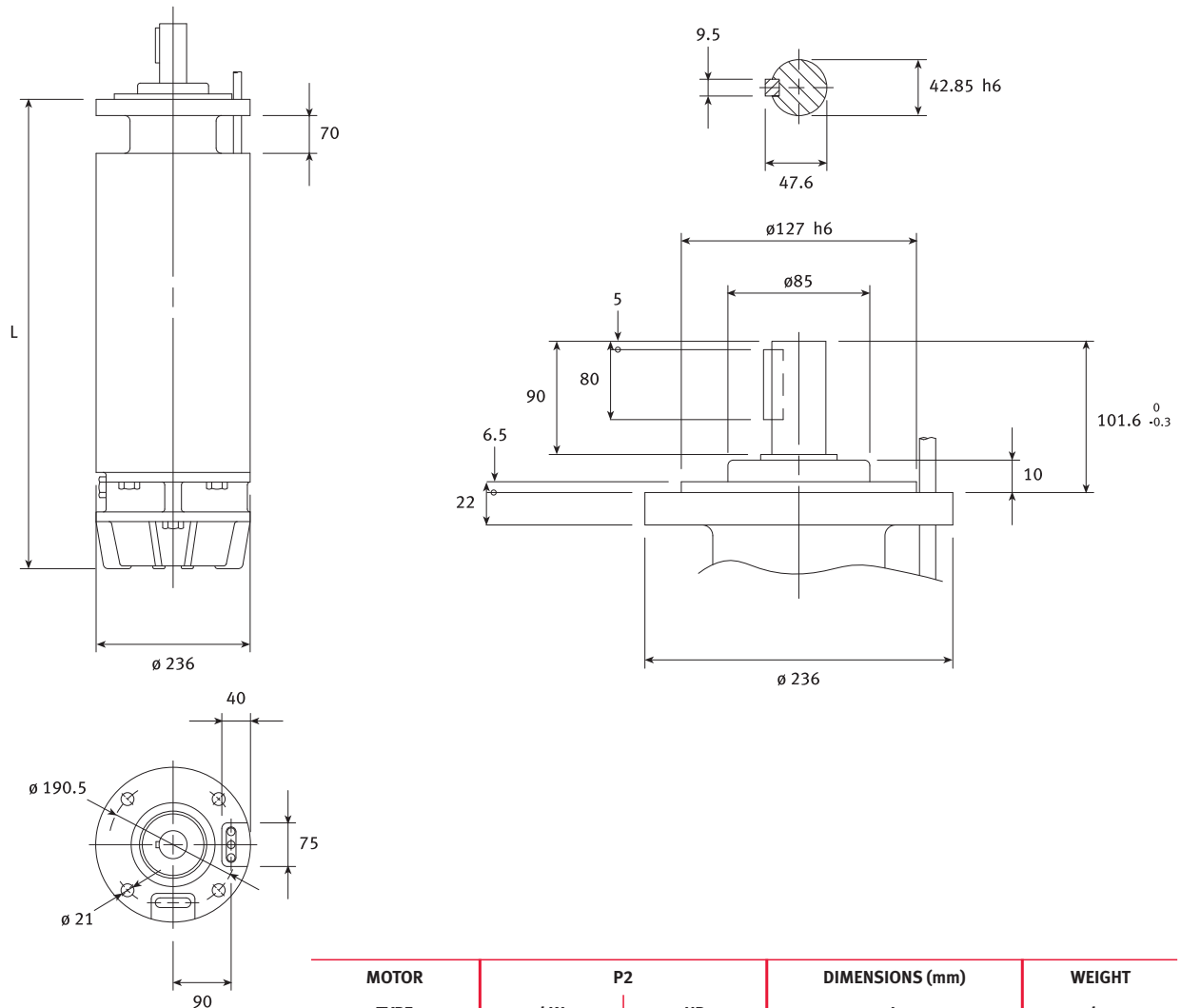

MOTOR TYPE	P2		DIMENSIONS (mm) L	WEIGHT kg
	kW	HP		
CP10 125	92	125	1562	360
CP10 150	110	150	1702	401
CP10 175	129	175	1852	448
CP10 200	150	200	1982	487

CP10 series motors operating characteristics 50 Hz

MOTOR TYPE	P2		REATED VOLTAGE V	OPERATING CHARACTERISSTICS				DIRECT START-UP		MAX. WATER TEMPERATURE °C	TYPE OF CABLE	
	kW	HP		RATED CURRENT A	rpm	η %	$\cos\phi$	Ca/Cn	Ia/In		Ncxsez. (mm ²)	L(m)
CP10 125	92	125	380	190	2910	85	0.85	1.02	5.3	25	3x35	5
			415	177	2910	85	0.85	1.06	5.31		3x35	5
CP10 150	110	150	380	237	2905	86.5	0.84	1.41	5.63	25	3X50	5
			415	216	2905	86.5	0.84	1.44	5.7		3X50	5
CP10 175	129	175	380	274	2915	86	0.83	1.57	5.8	25	3X70	5
			415	250	2915	86.5	0.83	1.54	5.78		3X70	5
CP10 200	150	200	380	312	2930	85	0.84	1.64	5.82	25	3X70	5
			415	292	2925	84.5	0.85	1.59	5.6		3X70	5

XS8 Series

Accessories

50 Hz

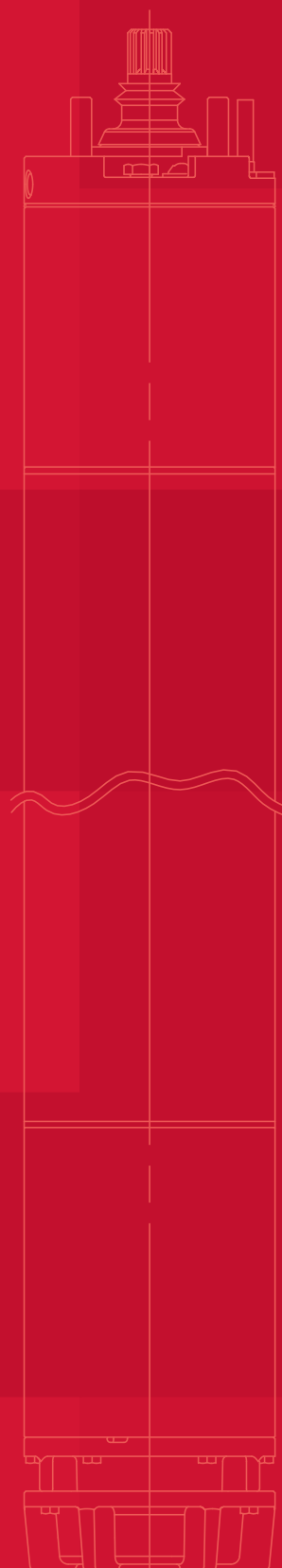

XS8 series ISO threaded flanges

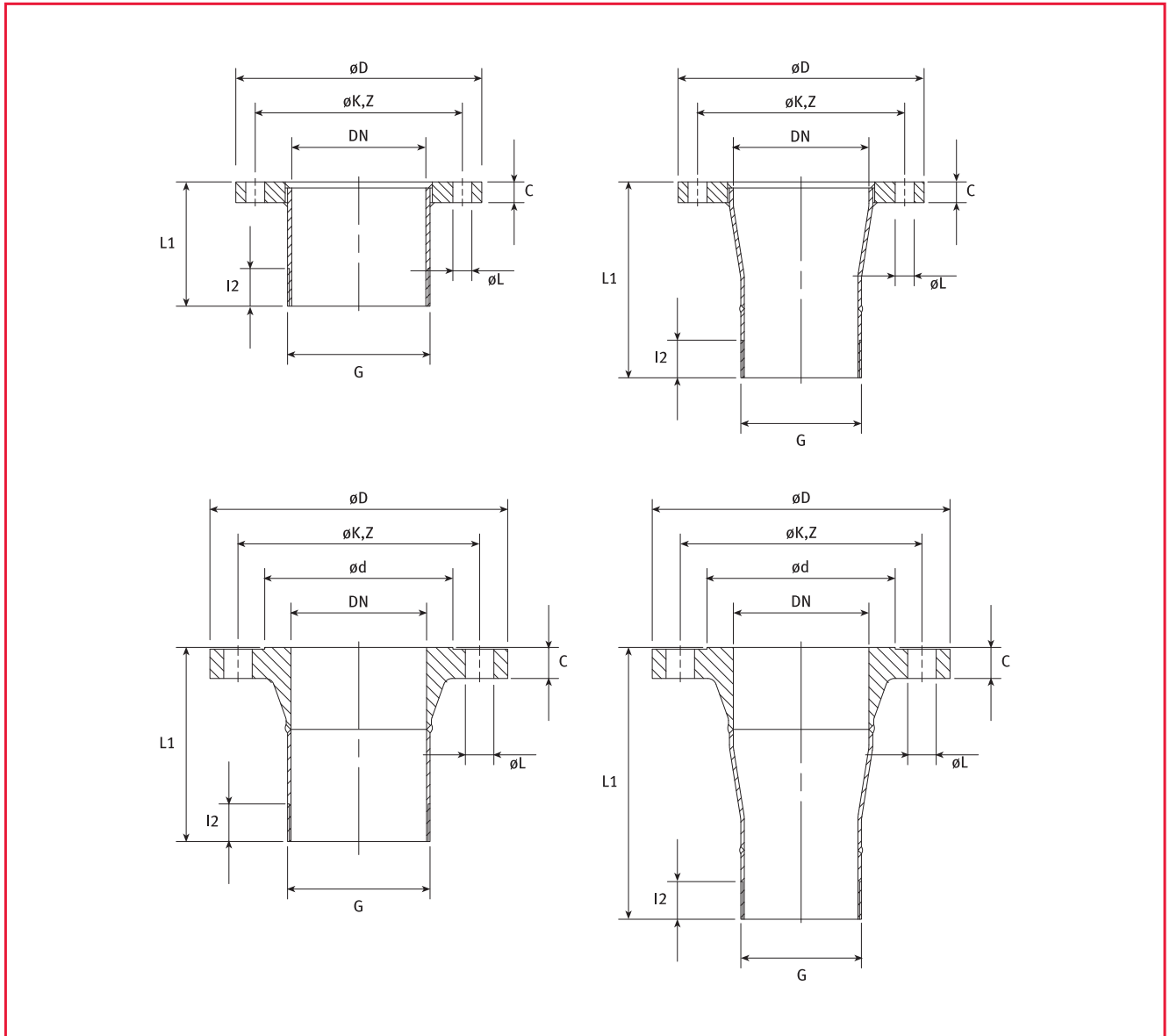

PUMP TYPE	THREADING	DIMENSIONS (mm)										
		* Flange in accordance with EN 1092-1										
		DN	PN	ø D	ø d	ø K	Z	ø L	C	L1	I2	TIPO
XS855 XS875 XS895 XS8125	G R5	125	10÷16	250		210	8	18	22	108	44	A
		125	25÷40	270	188	220	8	26	26	168	44	C
		125	63	295	188	240	8	30	34	188	44	C
		150	10÷16	285		240	8	22	22	248	44	B
		150	25÷40	300	218	250	8	26	28	315	44	D
		150	63	345	218	280	8	33	36	335	44	D

* Flanges in accordance with ASME B16.5 available on request.

XS8 series support flanges

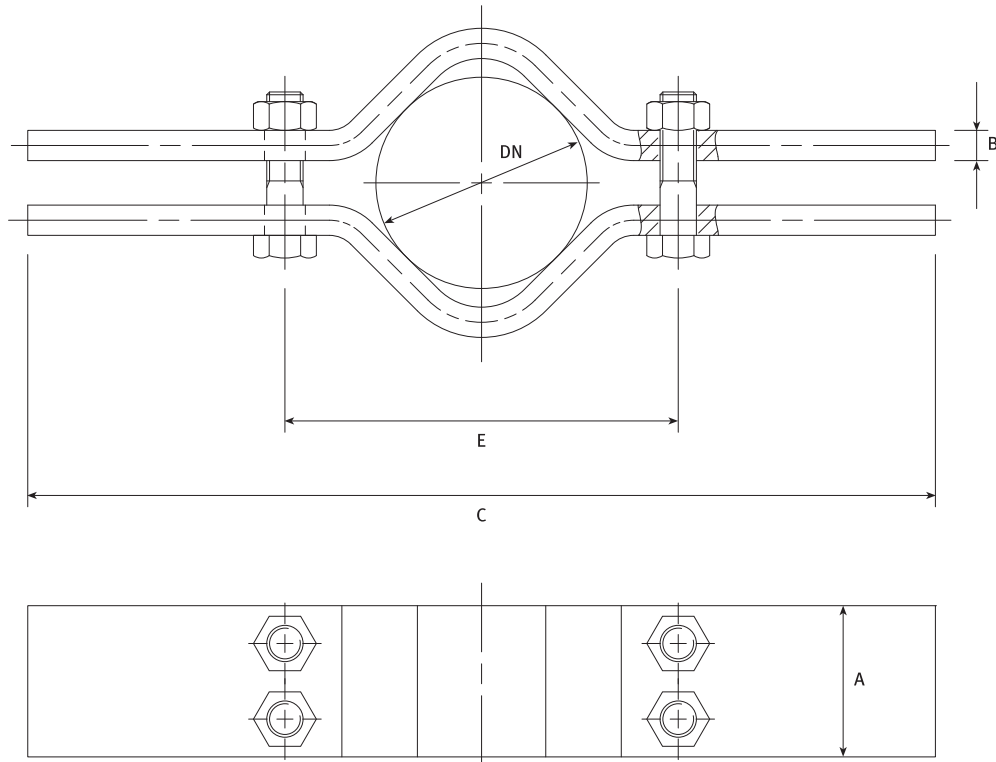

NOMINAL PIPE Ø		SUPPORT FLANGES						PIPE WEIGHT		
DN		DIMENSIONS (mm)				VITE	Pmax ⁽¹⁾ kg	Clamped kg/m	Threaded kg/m	Water kg/m
		A	B	C	E					
65	R2 1/2"	50	15	600	130	M16X90	1300	6.7	8	3.3
80	R 3"	80	15	600	180	M20X70	3400	8.4	10.5	5
100	R 4"	80	15	600	180	M20X110	3400	20.5	15	7.9
125	R 5"	100	20	600	260	M24X90	7250	27.5	18.5	12.3
150	R 6"	100	20	600	260	M24X130	7250	33	22	17.6
175	R 7"	120	25	800	360	M30X110	9750	27	25.5	24
200	R 8"	120	25	800	360	M30X150	9750	33	34	31.5
250	R 10"	120	25	800	360	M30X220	9750	48	48	49

1) Maximum weight admitted.

NOTE: 2 sets of support collars are necessary for the installation.

XS8 series water jackets

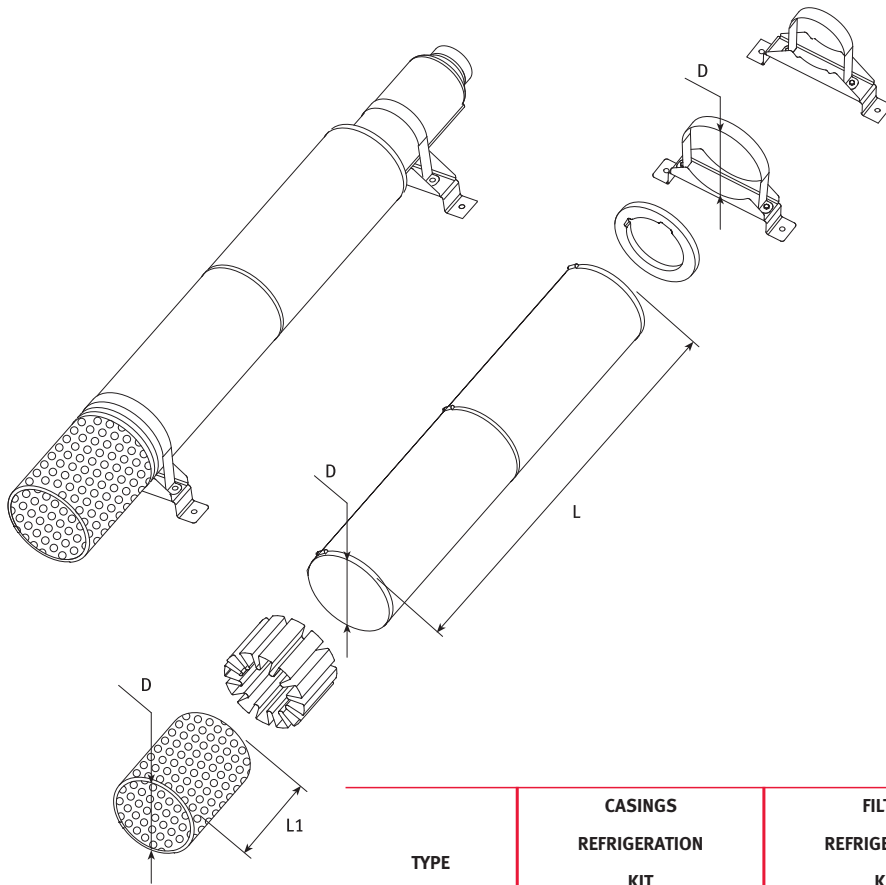

TYPE	CASINGS	FILTER	SUPPORT
	REFRIGERATION	REFRIGERATION	REFRIGERATION
	KIT	KIT	KIT
	D x L	D x L1	D
6"	D225x800	D225x192	D225
	D225x900	D225x192	D225
	D225x1000	D225x192	D225
	D225x1250	D225x192	D225
	D225x1500	D225x192	D225
	D225x1750	D225x192	D225
	D256x800	D256x325	D256
	D256x900	D256x325	D256
	D256x1000	D256x325	D256
	D256x1250	D256x325	D256
	D256x1500	D256x325	D256
D256x1750	D256x325	D256	
8"	D256x1250	D256x325	D256
	D256x1500	D256x325	D256
	D256x1750	D256x325	D256
	D256x2000	D256x325	D256
	D256x2250	D256x325	D256
	D285x1250	D285x385	D285
	D285x1500	D285x385	D285
	D285x1750	D285x385	D285
	D285x2000	D285x385	D285
D285x2500	D285x385	D285	
10"	D285x1750	D285x385	D285
	D330x1750	D330x385	D330
	D330x2000	D330x385	D330
	D330x2250	D330x385	D330

XS8 series motor coupling water jacket table for CP8 motors

MOTOR TYPE	PUMP TYPE	STAGES	CASING REFRIGERATION	FILTER REFRIGERATION	SUPPORT REFRIGERATION
			KIT	KIT	KIT
CP8	XS855 09	9	D256x1500	D256x325	D256 3PZ
	XS855 10/2A	10	D256x1500	D256x325	D256 3PZ
	XS855 10	10	D256x1500	D256x325	D256 3PZ
	XS855 1192A	11	D256x1500	D256x325	D256 3PZ
	XS855 11	11	D256x1500	D256x325	D256 3PZ
	XS855 12	12	D256x1500	D256x325	D256 3PZ
	XS855 13	13	D256x1750	D256x325	D256 3PZ
	XS855 14	14	D256x1750	D256x325	D256 3PZ
	XS855 15	15	D256x1750	D256x325	D256 3PZ
	XS855 16	16	D256x1750	D256x325	D256 3PZ
	XS855 17	17	D256x2000	D256x325	D256 3PZ
	XS855 18	18	D256x2000	D256x325	D256 3PZ
	XS855 19	19	D256x2000	D256x325	D256 3PZ
	XS875 08/2A	8	D256x1500	D256x325	D256 3PZ
	XS875 08	8	D256x1500	D256x325	D256 3PZ
	XS875 09/2A	9	D256x1500	D256x325	D256 3PZ
	XS875 09	9	D256x1500	D256x325	D256 3PZ
	XS875 10/2A	10	D256x1500	D256x325	D256 3PZ
	XS875 10	10	D256x1500	D256x325	D256 3PZ
	XS875 11/2A	11	D256x1500	D256x325	D256 3PZ
	XS875 11	11	D256x1750	D256x325	D256 3PZ
	XS875 12	12	D256x1750	D256x325	D256 3PZ
	XS875 13	13	D256x1750	D256x325	D256 3PZ
	XS875 14	14	D256x1750	D256x325	D256 3PZ
	XS875 15	15	D256x2000	D256x325	D256 3PZ
	XS875 16	16	D256x2000	D256x325	D256 3PZ
	XS875 17	17	D256x2000	D256x325	D256 3PZ
	XS895 06/3A	6	D285x1500	D285x385	D285 3PZ
	XS895 06	6	D285x1500	D285x385	D285 3PZ
	XS895 07/3A	7	D285x1500	D285x385	D285 3PZ
	XS895 07	7	D285x1500	D285x385	D285 3PZ
	XS895 08/3A	8	D285x1750	D285x385	D285 3PZ
	XS895 08	8	D285x1750	D285x385	D285 3PZ
	XS895 09/3A	9	D285x1750	D285x385	D285 3PZ
	XS895 09	9	D285x1750	D285x385	D285 3PZ
	XS895 10/3A	10	D285x1750	D285x385	D285 3PZ
	XS895 10	10	D285x1750	D285x385	D285 3PZ
	XS895 11	11	D285x2000	D285x385	D285 3PZ
	XS895 12	12	D285x2000	D285x385	D285 3PZ
	XS8125 03/3A	6	D285x1500	D285x385	D285 3PZ
	XS8125 06	6	D285x1500	D285x385	D285 3PZ
	XS8125 07/3A	7	D285x1500	D285x385	D285 3PZ
	XS8125 07	7	D285x1500	D285x385	D285 3PZ
	XS8125 08/3A	8	D285x1500	D285x385	D285 3PZ
	XS8125 08	8	D285x1750	D285x385	D285 3PZ
	XS8125 09/3A	9	D285x1750	D285x385	D285 3PZ
	XS8125 09	9	D285x1750	D285x385	D285 3PZ
	XS8125 10/3A	10	D285x1750	D285x385	D285 3PZ
XS8125 10	10	D285x1750	D285x385	D285 3PZ	
XS8125 11	11	D285x2000	D285x385	D285 3PZ	
XS8125 12	12	D285x2000	D285x385	D285 3PZ	

Horizontal installation not possible. The supports must be used solely for fastening the electropump vertically.

XS8 series motor coupling water jacket table for CP10 motors

MOTOR TYPE	PUMP TYPE	STAGES	CASING REFRIGERATION KIT	FILTER REFRIGERATION KIT	SUPPORT REFRIGERATION KIT
CP10	XS875 18	18	D285x1750	D285x385	D285 3PZ
	XS895 13	13	D330x2000	D330x385	D330 3PZ
	XS895 14	14	D330x2000	D330x385	D330 3PZ
	XS895 15	15	D330x2250	D330x385	D330 3PZ
	XS895 16	16	D330x2250	D330x385	D330 3PZ
	XS895 17	17	D330x2250	D330x385	D330 3PZ
	XS895 18	18	D330x2250	D330x385	D330 3PZ
	XS8125 13	13	D330x2000	D330x385	D330 3PZ
	XS8125 14	14	D330x2000	D330x385	D330 3PZ
	XS8125 15	15	D330x2000	D330x385	D330 3PZ
	XS8125 16	16	D330x2250	D330x385	D330 3PZ
	XS8125 17	17	D330x2250	D330x385	D330 3PZ
	XS8125 18	18	D330x2250	D330x385	D330 3PZ

Horizontal installation not possible. The supports must be used solely for fastening the electropump vertically.



COLLECTING
MAKING POTABLE
PRESSURISING
RECIRCULATING
REUSING
EVACUATING
CLEANING

ESPA GROUP supporting you
with all the technology,
products and service you need.