

Drainex 300 Drainage



Submersible monobloc pumps, Vortex system

Applications

Drainage of sewage and dirty water, operation in septic tanks and small purifying installations.

Materials

Pump body, discharge body, suction body and impeller in cast iron.
Mechanical seal in silicon carbide and ceramic.
Pump base in AISI 304 stainless steel, detachable for coupling of accessories.
O-rings in NBR.
Motor shaft in AISI 420 stainless steel.

Motor

Asynchronous, 2 poles.
IP 68 protection.
Class F insulation.
Continuous operation.
Water-cooled motor.
Single-phase version with built-in thermal protection and capacitor.

Equipment

Supplied with 10 m power cable.
Drainex 300 M A: complete with float switch.

Limitations

Maximum solid-handling capacity: 60 mm.
Maximum liquid temperature: 40 °C.

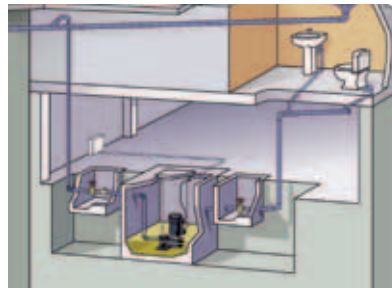

Dimensions and weights

Model	A	B	C	D	E	F	G	H	I	J	kg
Drainex 300	429	271,5	408	118,7	222	110	150	110	144	2 1/2"	28
Drainex 301	429	271,5	408	118,7	222	110	150	110	144	2 1/2"	28
Drainex 302	429	271,5	408	118,7	222	110	150	110	144	2 1/2"	28

Impeller ext. Ø: Drainex 300: 105 mm. Drainex 301: 115 mm. Drainex 302: 124 mm.

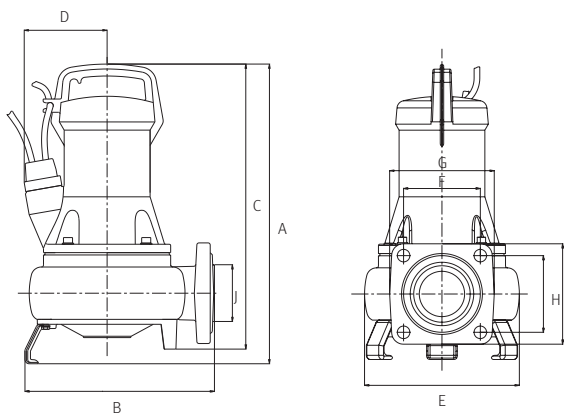

Performance curves at 2900 rpm

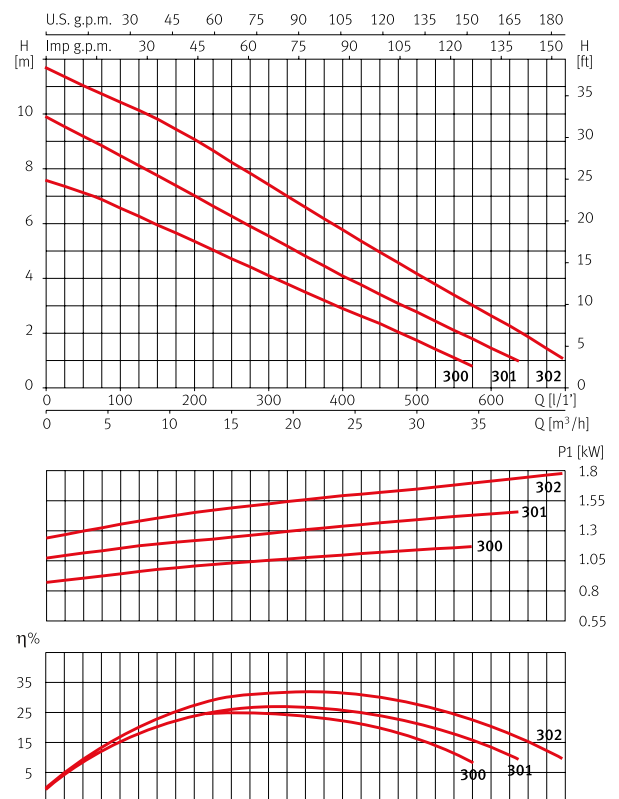

Hydraulic performance table

Model	I (A)		P1 (kW)		P2		µF	l/min m³/h	50	100	200	300	400	500	600	650
	1~ 230 V	3~ 400 V	1~	3~	(kW)	(HP)			mwc	3,0	6,0	12	18	24	30	36
Drainex 300	5,5	2,4	1,2	1,2	1,1	1,5	16	mwc	7,1	6,6	5,4	4,1	2,9	1,8		
Drainex 301	6,8	2,7	1,5	1,5	1,1	1,5	16		9,2	8,5	7	5,6	4,1	2,8	1,5	
Drainex 302	7,8	3	1,8	1,8	1,1	1,5	16		11	10,5	9	7,4	5,8	4,2	2,6	1,8

Portable version

A	B	C	D	E	F	G	H	I	J	K	L	M
455	373	108	213	105	101	62	111	111	150	110	110	144

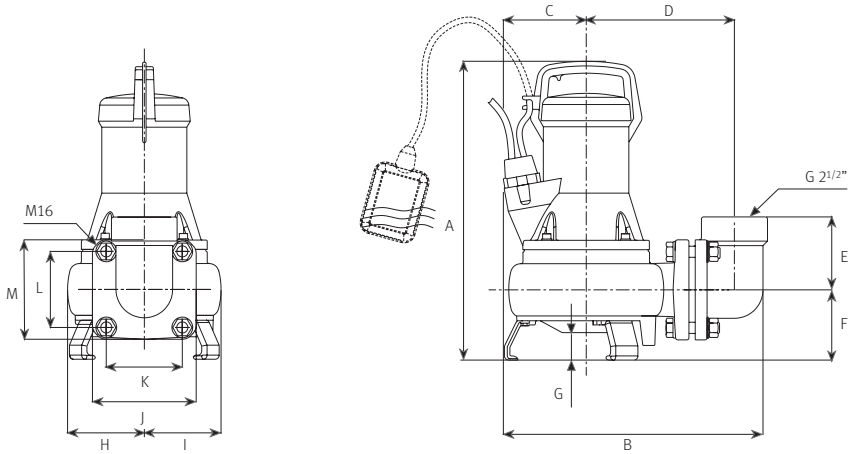

Passage \varnothing of particles in suspension: 45 mm. - Drainex 300 A: supplied built-in float switch

Fixed version

A	B	C	D	E	F	G	H	I	J	K	L	M	N	O	P	Q	R	S	T	U	V	W	X	Y	Z
405	441	108	245,5	92	132	11,5	74,5	15	38	70	$\varnothing 12$	85	12	$\varnothing 42$	85	$\varnothing 10$	111	111	104	56	11	50,5	20,5	50	95

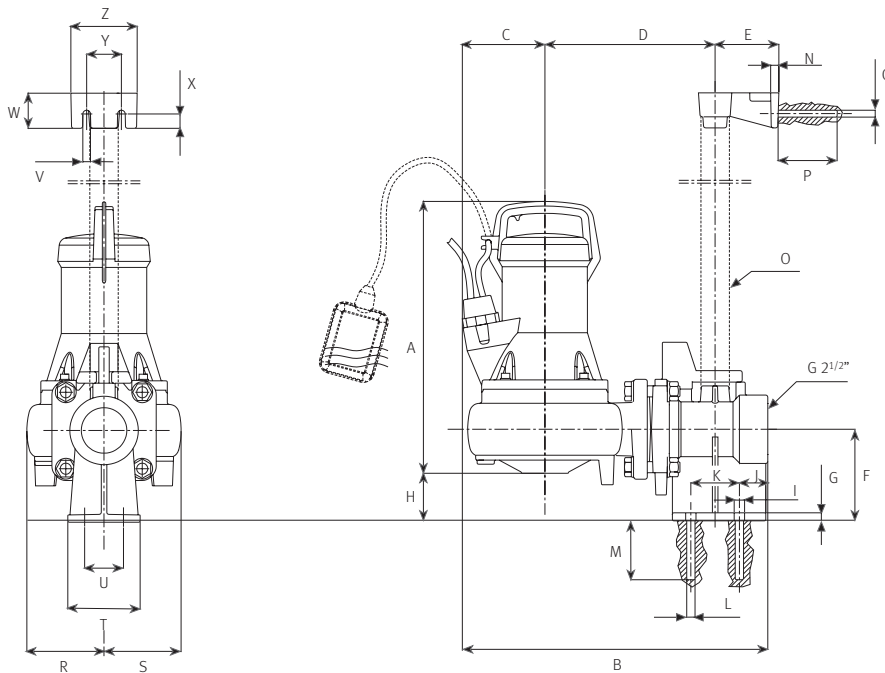

Passage \varnothing of particles in suspension: 60 mm. - Drainex 300 A: supplied built-in float switch

Accessories Fixed version

DR2 Kit



Support base for automatic anchoring.



Clamping flange.



Upper anchoring on guide tube.