

Acuaplus N Pressurization



Submersible multistage pumps with speed control

Applications

Pressurising of domestic water for houses, semi-detached homes, apartments, chalets and rural homes...

Materials

Outer casing, discharge body, impellers, filter, discharge cover and motor casing in AISI 304 stainless steel.

Motor shaft in AISI 303 stainless steel + F-114 steel. Diffusers in PPO.

Mechanical seal in aluminium oxide/graphite/steatite/NBR/AISI 304.

Motor

Asynchronous, 2 pole.

IP 68 protection.

Class F insulation.

Continuous operation.

Water-cooled motor.

Single-phase version with Klixon (incorporated thermal protection).

With level switch.

Equipment

Multistage submersible pump with electronic variable speed regulation and integrated pressure sensor for constant pressure.

Incorporating a detection and protection device against functioning in dry operation, with sequential start-up attempts in the event of failure.

Reduce the water hammer effect on the installation. Oil chamber with double mechanical seal.

Limitations

Maximum working pressure 8 bar.

Ø of solids 2 mm.

Water temperature from 4 °C to 35 °C.

Maximum start-ups: 30/hour.

Vertical or horizontal installation.



Dimensions and weights

Model	A	B	C	D	E	F	kg
Acuaplus N	517	160	1"	170	254	175	11,5

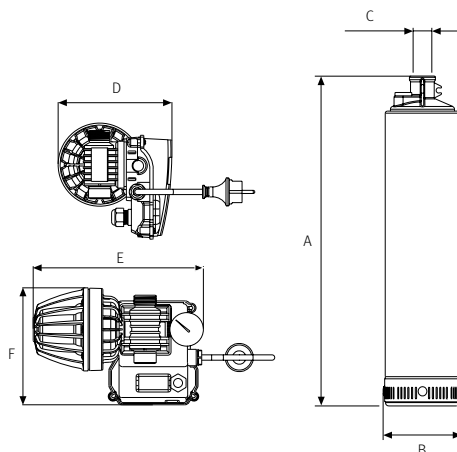

Performance curves at 2900 rpm

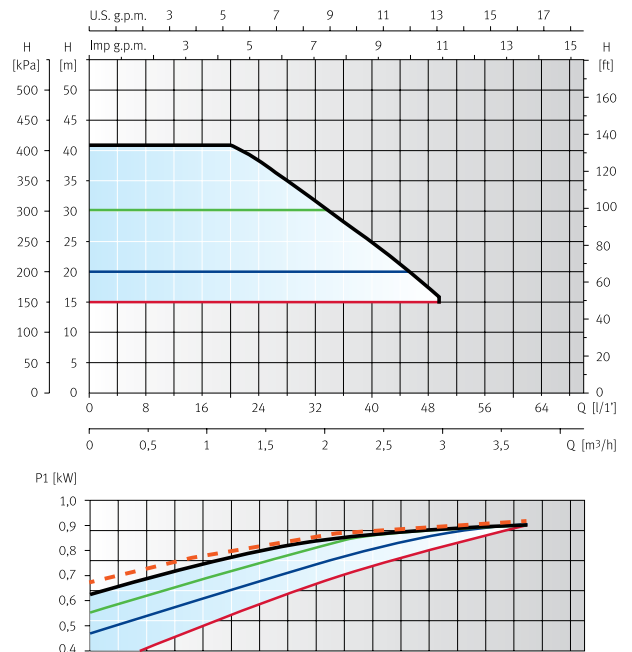

The pump can operate at any point inside the indicated area. The characteristic curves depend on the delivery pressure. By way of example, the curves are shown for delivery pressures of 150, 200 and 300 kPa. The operating-limit curve corresponds to the maximum rotating speed.

Hydraulic performance table

Model	I (A)	P1 (kW)	P2		μF	l/min	10	20	40	50	60
	1~ 230 V	1~	(kW)	(HP)		m³/h	0,6	1,2	2,4	3,0	3,6
Acuaplus N	4,4	1	0,75	1	12	MAX	40	40	34	25	
						MIN	15	15	15	15	15